

SIGNALS AND SYSTEMS

**B.TECH
(II YEAR – I SEM)
(2019-20)**

Department of Electronics and Communication Engineering



MALLA REDDY COLLEGE OF ENGINEERING & TECHNOLOGY

(Autonomous Institution – UGC, Govt. of India)

Recognized under 2(f) and 12 (B) of UGC ACT 1956

(Affiliated to JNTUH, Hyderabad, Approved by AICTE - Accredited by NBA & NAAC – 'A' Grade - ISO 9001:2015 Certified)
Maisammaguda, Dhulapally (Post Via. Kompally), Secunderabad – 500100, Telangana State, India

MALLA REDDY COLLEGE OF ENGINEERING AND TECHNOLOGY

II Year B.Tech ECE-I Sem

L	T/P/D	C
3	-/-/-	3

(R18A0402) SIGNALS AND SYSTEMS

OBJECTIVES:

The main objectives of the course are:

1. Coverage of continuous and discrete-time signals and representations and methods that is necessary for the analysis of continuous and discrete-time signals.
2. Knowledge of time-domain representation and analysis concepts as they relate to difference equations, impulse response and convolution, etc.
3. Knowledge of frequency-domain representation and analysis concepts using Fourier analysis tools, Z-transform.
4. Concepts of the sampling process.
5. Mathematical and computational skills needed in application areas like communication, signal processing and control, which will be taught in other courses.

UNIT I:

INTRODUCTION TO SIGNALS: Elementary Signals- Continuous Time (CT) signals, Discrete Time (DT) signals, Classification of Signals, Basic Operations on signals,.

FOURIER SERIES: Representation of Fourier series, Continuous time periodic signals, Dirichlet's conditions, Trigonometric Fourier Series, Exponential Fourier Series, Complex Fourier spectrum.

UNIT II:

FOURIER TRANSFORMS: Deriving Fourier transform from Fourier series, Fourier transform of arbitrary signal, Fourier transform of standard signals, Fourier transform of periodic signals, Properties of Fourier transforms.

SAMPLING: Sampling theorem – Graphical and analytical proof for Band Limited Signals, impulse sampling, Natural and Flat top Sampling, Reconstruction of signal from its samples, effect of under sampling – Aliasing.

UNIT III:

SIGNAL TRANSMISSION THROUGH LINEAR SYSTEMS: Introduction to Systems, Classification of Systems, Linear Time Invariant (LTI) systems, impulse response, Transfer function of a LTI system. Filter characteristics of linear systems. Distortion less transmission through a system, Signal bandwidth, System bandwidth, Ideal LPF, HPF and BPF characteristics

UNIT IV:

CONVOLUTION AND CORRELATION OF SIGNALS: Concept of convolution in time domain, Cross correlation and auto correlation of functions, properties of correlation function, Energy density spectrum, Parseval's theorem, Power density spectrum, Relation between convolution and correlation

UNIT V:

LAPLACE TRANSFORMS: Review of Laplace transforms, Inverse Laplace transform, Concept of region of convergence (ROC) for Laplace transforms, Properties of L.T's relation between L.T's, and F.T. of a signal.

Z-TRANSFORMS: Concept of Z- Transform of a discrete sequence. Distinction between Laplace, Fourier and Z transforms, Region of convergence in Z-Transform, Inverse Z- Transform, Properties of Z-transforms.

TEXT BOOKS:

1. "Signals & Systems", Special Edition – MRCET, McGraw Hill Publications, 2017
2. Signals, Systems & Communications - B.P. Lathi, BS Publications, 2003.
3. Signals and Systems - A.V. Oppenheim, A.S. Willsky and S.H. Nawab, PHI, 2nd Edn.
4. Signals and Systems – A. Anand Kumar, PHI Publications, 3rd edition.

REFERENCE BOOKS:

1. Signals & Systems - Simon Haykin and Van Veen, Wiley, 2nd Edition.
2. Network Analysis - M.E. Van Valkenburg, PHI Publications, 3rd Edn., 2000.
3. Fundamentals of Signals and Systems Michel J. Robert, MGH International Edition, 2008.
4. Signals, Systems and Transforms - C. L. Philips, J. M. Parr and Eve A. Riskin, Pearson education. 3rd Edition, 2004.

OUTCOMES:

After completion of the course, the student will be able to:

1. Represent any arbitrary signals in terms of complete sets of orthogonal functions and understands
2. Arbitrary signal (discrete) as Fourier transform to draw the spectrum.
3. Concepts of auto correlation and cross correlation and power Density Spectrum.
4. For a given system, response can be obtained using Laplace transform, properties and ROC of L.T.
5. Study the continuous and discrete signal relation and relation between F.T., L.T. & Z.T, properties, ROC of Z Transform

What is Signal?

Signal is a time varying physical phenomenon which is intended to convey information.

OR

Signal is a function of time.

OR

Signal is a function of one or more independent variables, which contain some information.

Example: voice signal, video signal, signals on telephone wires etc.

Note: Noise is also a signal, but the information conveyed by noise is unwanted hence it is considered as undesirable.

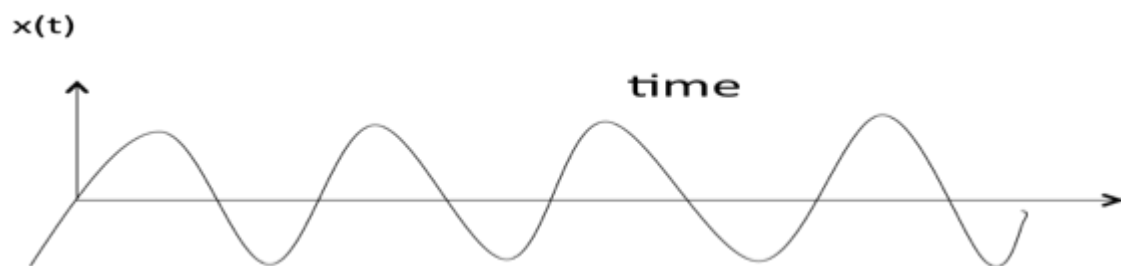

What is System?

System is a device or combination of devices, which can operate on signals and produces corresponding response. Input to a system is called as excitation and output from it is called as response.

For one or more inputs, the system can have one or more outputs.

Example: Communication System

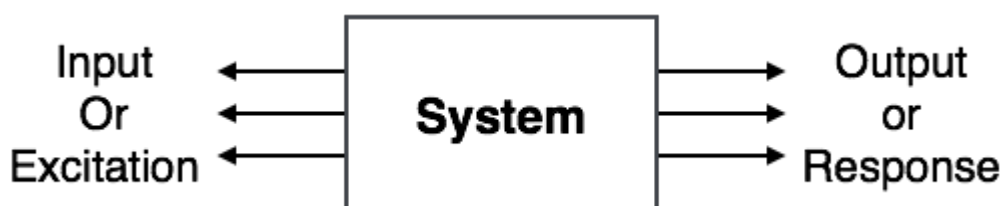

SIGNALS CLASSIFICATION

Signals are classified into the following categories:

- Continuous Time and Discrete Time Signals
- Deterministic and Non-deterministic Signals
- Even and Odd Signals
- Periodic and Aperiodic Signals
- Energy and Power Signals
- Real and Imaginary Signals

Continuous Time and Discrete Time Signals

A signal is said to be continuous when it is defined for all instants of time.

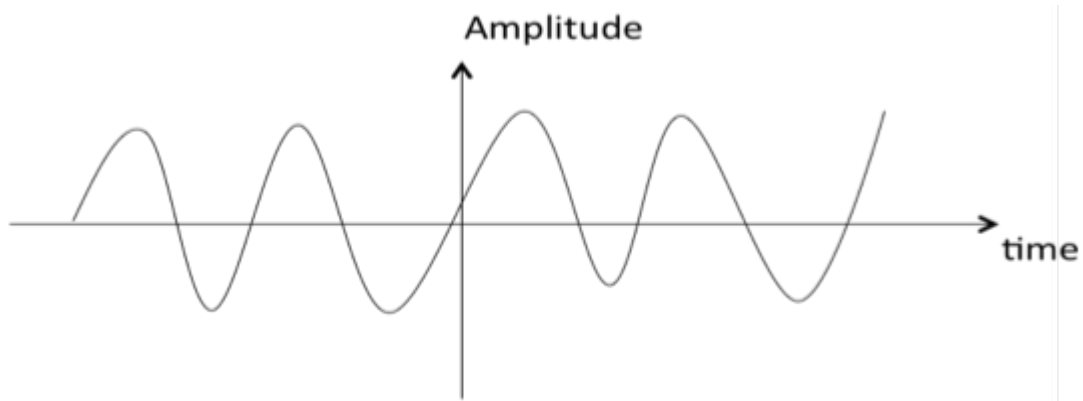

A signal is said to be discrete when it is defined at only discrete instants of time/

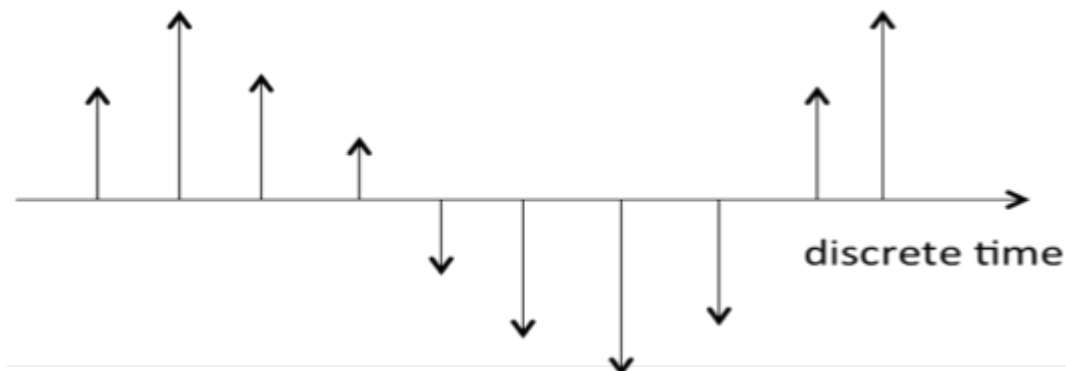

Deterministic and Non-deterministic Signals

A signal is said to be deterministic if there is no uncertainty with respect to its value at any instant of time. Or, signals which can be defined exactly by a mathematical formula are known as deterministic signals.

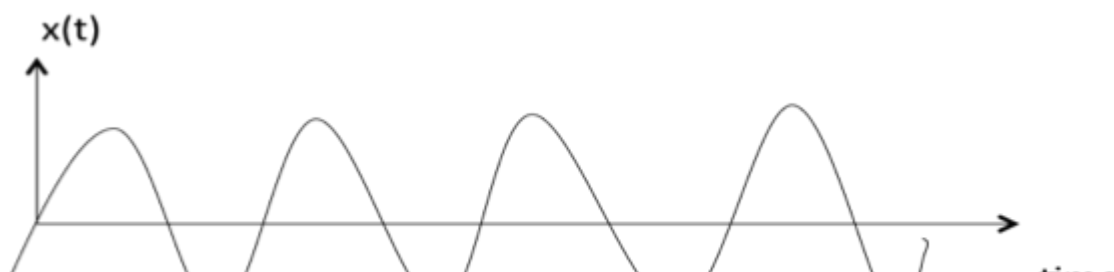

A signal is said to be non-deterministic if there is uncertainty with respect to its value at some instant of time. Non-deterministic signals are random in nature hence they are called random signals. Random signals cannot be described by a mathematical equation. They are modelled in probabilistic terms.

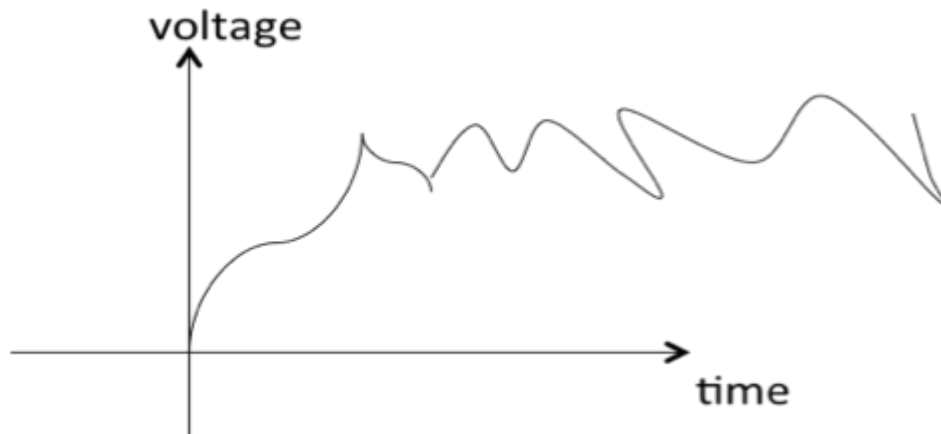

Even and Odd Signals

A signal is said to be even when it satisfies the condition $x(t) = x(-t)$

Example 1: t^2, t^4, \dots cost etc.

$$\text{Let } x(t) = t^2$$

$$x(-t) = (-t)^2 = t^2 = x(t)$$

\therefore, t^2 is even function

Example 2: As shown in the following diagram, rectangle function $x(t) = x(-t)$ so it is also even function.

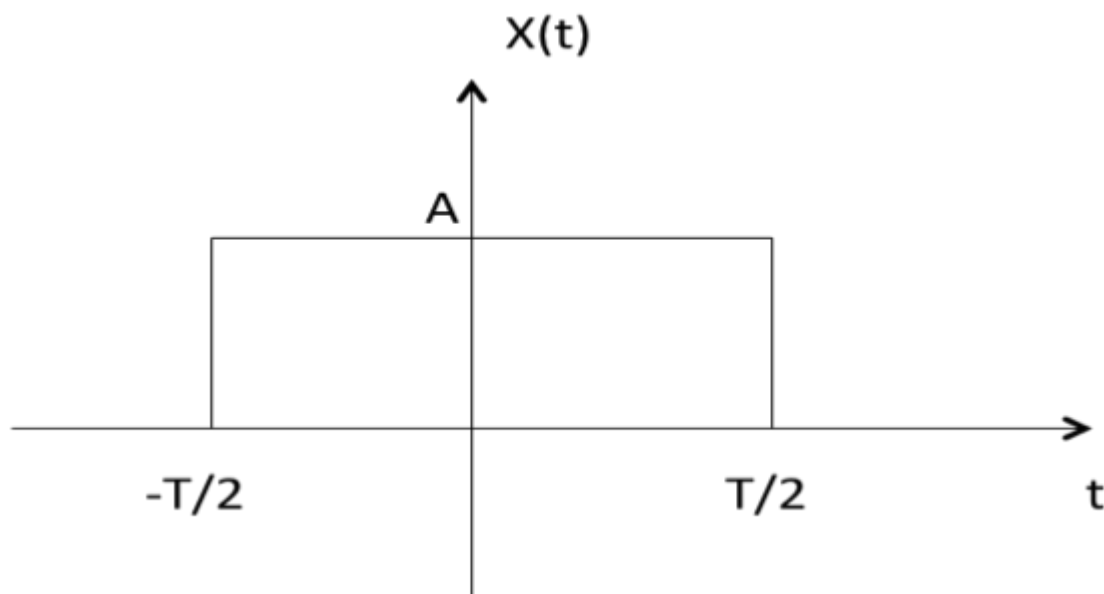

A signal is said to be odd when it satisfies the condition $x(t) = -x(-t)$

Example: t, t^3, \dots And $\sin t$

$$\text{Let } x(t) = \sin t$$

$$x(-t) = \sin(-t) = -\sin t = -x(t)$$

$\therefore, \sin t$ is odd function.

Any function $f(t)$ can be expressed as the sum of its even function $f_e(t)$ and odd function $f_o(t)$.

$$f(t) = f_e(t) + f_o(t)$$

where

$$f_e(t) = \frac{1}{2}[f(t) + f(-t)]$$

Periodic and Aperiodic Signals

A signal is said to be periodic if it satisfies the condition $x(t) = x(t + T)$ or $x(n) = x(n + N)$.

Where

T = fundamental time period,

$1/T = f =$ fundamental frequency.

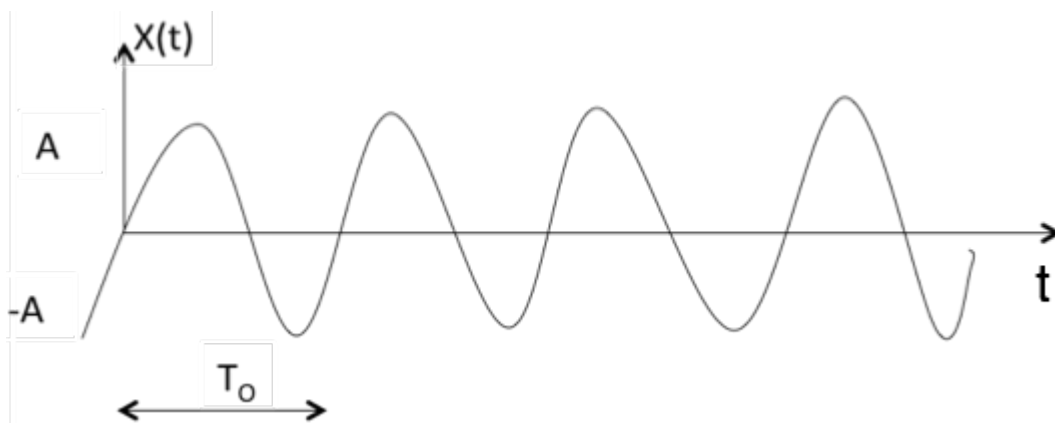

The above signal will repeat for every time interval T_0 hence it is periodic with period T_0 .

Energy and Power Signals

A signal is said to be energy signal when it has finite energy.

$$\text{Energy } E = \int_{-\infty}^{\infty} x^2(t) dt$$

A signal is said to be power signal when it has finite power.

$$\text{Power } P = \lim_{T \rightarrow \infty} \frac{1}{2T} \int_{-T}^T x^2(t) dt$$

NOTE: A signal cannot be both, energy and power simultaneously. Also, a signal may be neither energy nor power signal.

Power of energy signal = 0

Energy of power signal = ∞

Real and Imaginary Signals

A signal is said to be real when it satisfies the condition $x(t) = x^*(t)$

A signal is said to be odd when it satisfies the condition $x(t) = -x^*(t)$

Example:

If $x(t) = 3$ then $x^*(t) = 3^* = 3$ here $x(t)$ is a real signal.

If $x(t) = 3j$ then $x^*(t) = 3j^* = -3j = -x(t)$ hence $x(t)$ is an odd signal.

Note: For a real signal, imaginary part should be zero. Similarly for an imaginary signal, real part should be zero.

SIGNALS BASIC TYPES

Here are a few basic signals:

Unit Step Function

Unit step function is denoted by $u(t)$. It is defined as $u(t) = \begin{cases} 1 & t \geq 0 \\ 0 & t < 0 \end{cases}$



- It is used as best test signal.
- Area under unit step function is unity.

Unit Impulse Function

Impulse function is denoted by $\delta(t)$, and it is defined as $\delta(t) = \begin{cases} 1 & t = 0 \\ 0 & t \neq 0 \end{cases}$

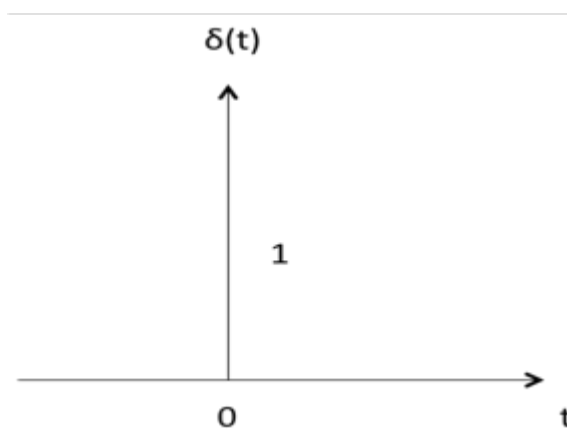

$$\int_{-\infty}^{\infty} \delta(t) dt = u(t)$$

$$\delta(t) = \frac{du(t)}{dt}$$

Ramp Signal

Ramp signal is denoted by rt , and it is defined as $rt = \begin{cases} t & t \geq 0 \\ 0 & t < 0 \end{cases}$

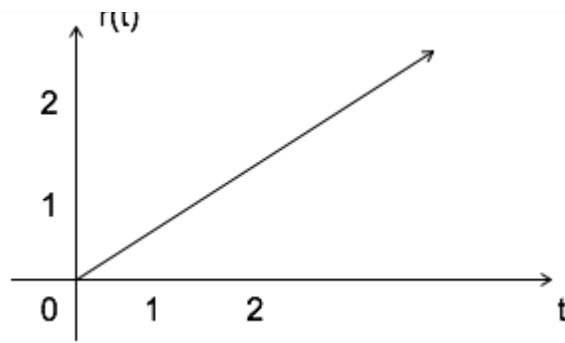

$$\int u(t) = \int 1 = t = r(t)$$

$$u(t) = \frac{dr(t)}{dt}$$

Area under unit ramp is unity.

Parabolic Signal

Parabolic signal can be defined as $x(t) = \begin{cases} t^2/2 & t \geq 0 \\ 0 & t < 0 \end{cases}$

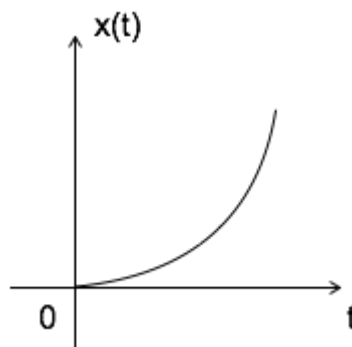

$$\iint u(t) dt = \int r(t) dt = \int t dt = \frac{t^2}{2} = \text{parabolicsignal}$$

$$\Rightarrow u(t) = \frac{d^2 x(t)}{dt^2}$$

$$\Rightarrow r(t) = \frac{dx(t)}{dt}$$

Signum Function

Signum function is denoted as $\text{sgn}t$. It is defined as $\text{sgn}t = \begin{cases} 1 & t > 0 \\ 0 & t = 0 \\ -1 & t < 0 \end{cases}$

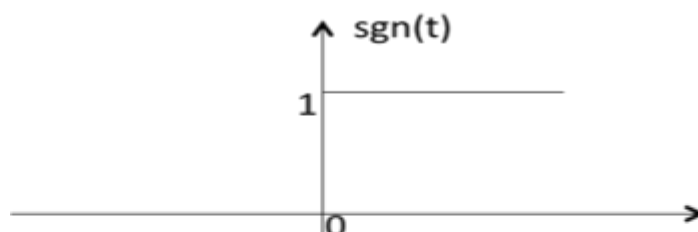



$$sgnt = 2ut - 1$$

Exponential Signal

Exponential signal is in the form of $x(t) = e^{\alpha t}$.

The shape of exponential can be defined by α .

Case i: if $\alpha = 0 \rightarrow x(t) = e^0 = 1$

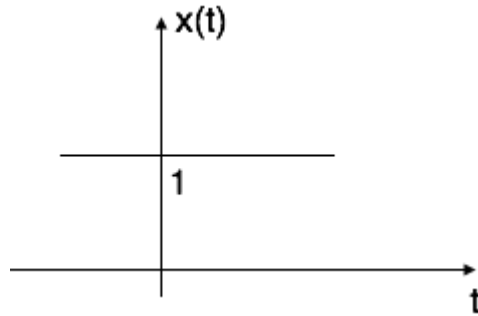

Case ii: if $\alpha < 0$ i.e. -ve then $x(t) = e^{-\alpha t}$. The shape is called decaying exponential.

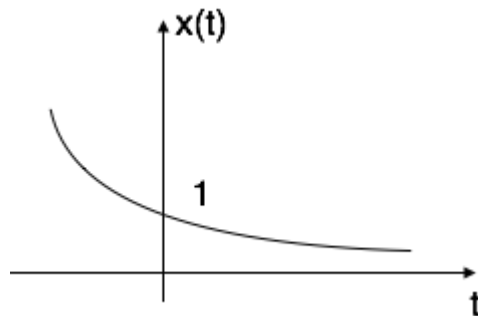

Case iii: if $\alpha > 0$ i.e. +ve then $x(t) = e^{\alpha t}$. The shape is called raising exponential.

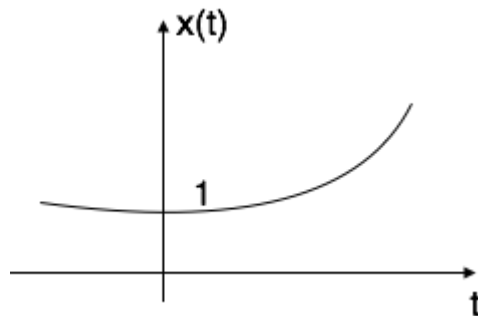

Rectangular Signal

Let it be denoted as $x(t)$ and it is defined as

$$x(t) = A \text{ rect} \left[\frac{t}{T} \right]$$

$$\text{ex: } 4 \text{ rect} \left[\frac{t}{6} \right]$$

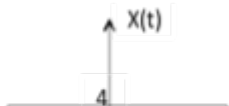
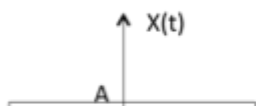



Triangular Signal

Let it be denoted as $x(t)$

$$x(t) = A \left[1 - \frac{|t|}{T} \right]$$

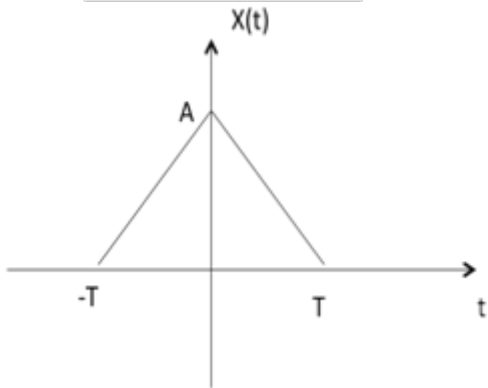

$$\text{ex: } x(t) = A \left[1 - \frac{|t|}{5} \right]$$

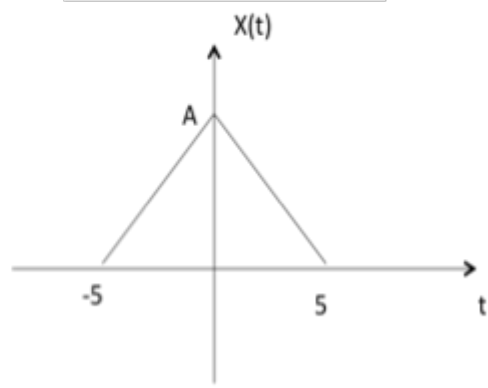

Sinusoidal Signal

Sinusoidal signal is in the form of $x(t) = A \cos(\omega_0 t \pm \phi)$ or $A \sin(\omega_0 t \pm \phi)$

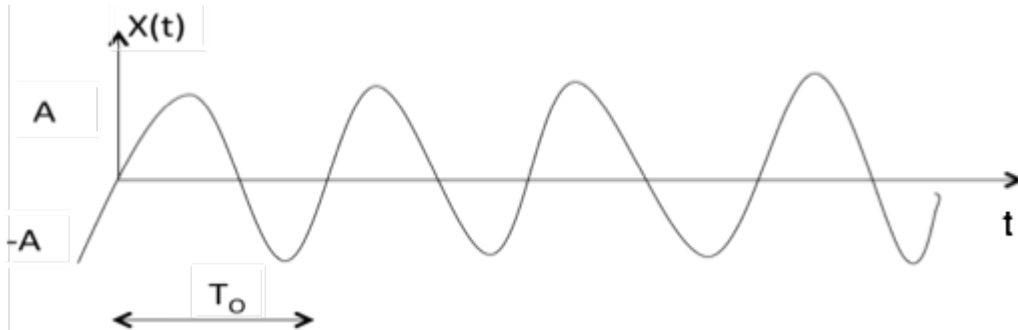

Where $T_0 = \frac{2\pi}{\omega_0}$

Sinc Function

It is denoted as $\text{sinc}(t)$ and it is defined as

$$\text{sinc}(t) = \frac{\sin \pi t}{\pi t}$$

$$= 0 \text{ for } t = \pm 1, \pm 2, \pm 3, \dots$$

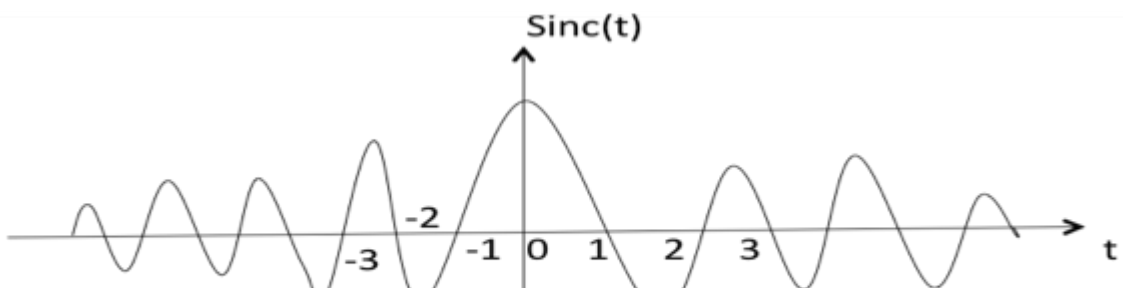

Sampling Function

It is denoted as sac and it is defined as

$$\text{sac}(t) = \frac{\sin t}{t}$$

$$= 0 \text{ for } t = \pm\pi, \pm2\pi, \pm3\pi \dots$$

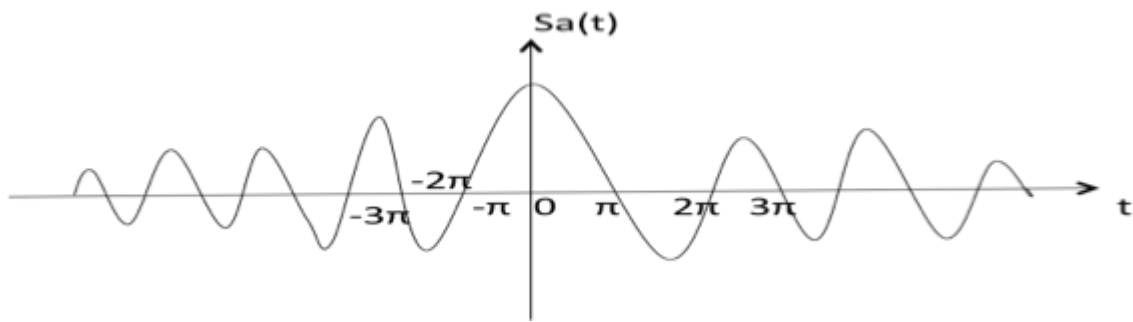

SIGNALS BASIC OPERATIONS

There are two variable parameters in general:

1. Amplitude
2. Time

The following operation can be performed with amplitude:

Amplitude Scaling

$Cx(t)$ is a amplitude scaled version of $x(t)$ whose amplitude is scaled by a factor C .

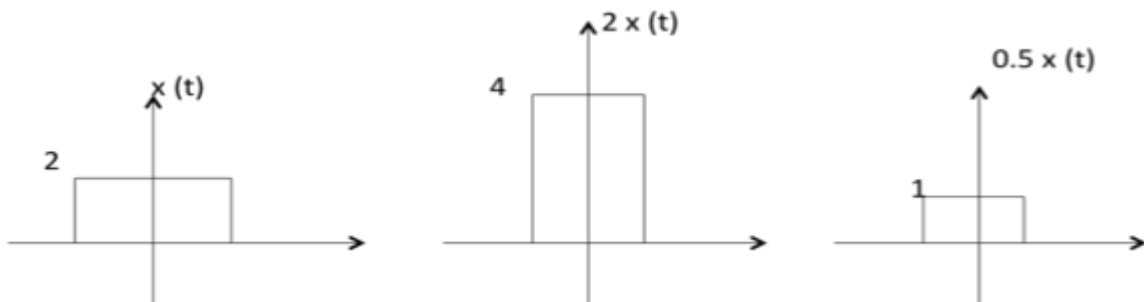

Addition

Addition of two signals is nothing but addition of their corresponding amplitudes. This can be best explained by using the following example:

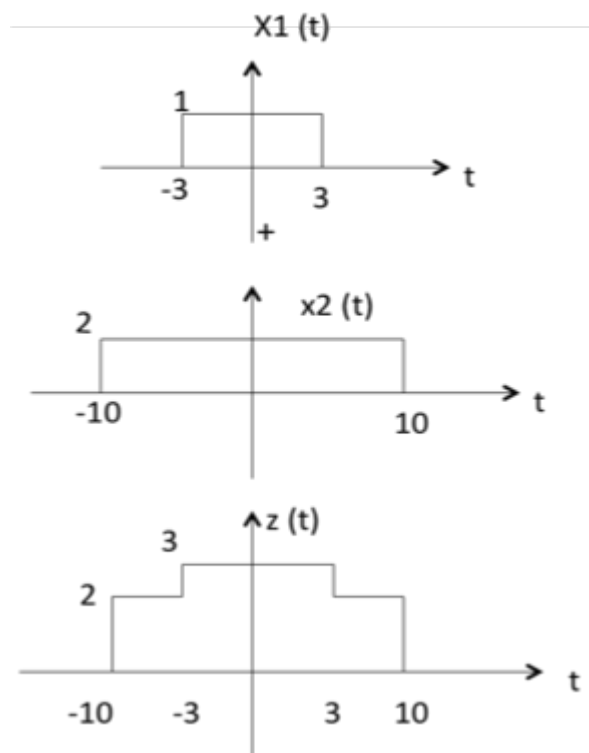

As seen from the diagram above,

$$-10 < t < -3 \text{ amplitude of } z(t) = x_1(t) + x_2(t) = 0 + 2 = 2$$

$$-3 < t < 3 \text{ amplitude of } z(t) = x_1(t) + x_2(t) = 1 + 2 = 3$$

$$3 < t < 10 \text{ amplitude of } z(t) = x_1(t) + x_2(t) = 0 + 2 = 2$$

Subtraction

subtraction of two signals is nothing but subtraction of their corresponding amplitudes. This can be best explained by the following example:

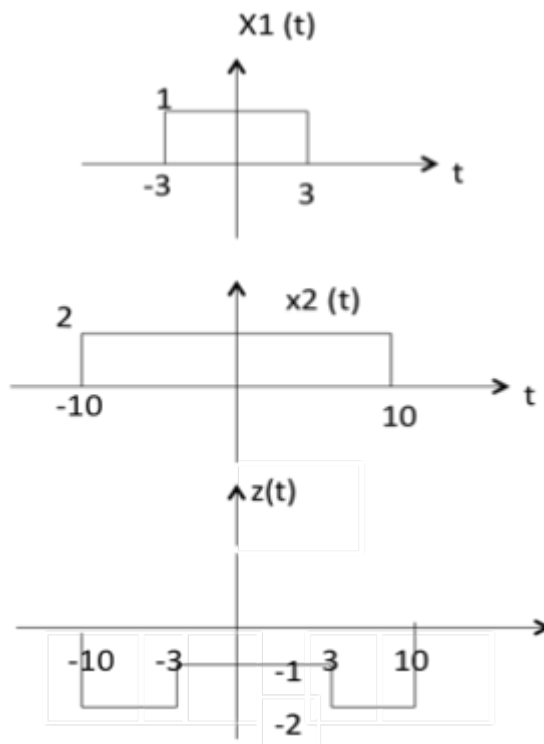

As seen from the diagram above,

$$-10 < t < -3 \text{ amplitude of } z(t) = x1(t) - x2(t) = 0 - 2 = -2$$

$$-3 < t < 3 \text{ amplitude of } z(t) = x1(t) - x2(t) = 1 - 2 = -1$$

$$3 < t < 10 \text{ amplitude of } z(t) = x1(t) - x2(t) = 0 - 2 = -2$$

Multiplication

Multiplication of two signals is nothing but multiplication of their corresponding amplitudes. This can be best explained by the following example:

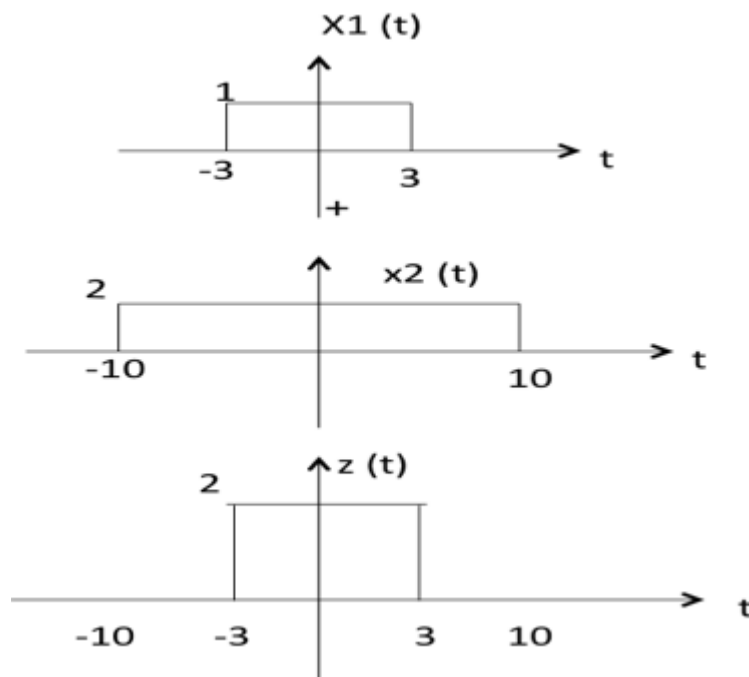

As seen from the diagram above,

$-10 < t < -3$ amplitude of $z(t) = x_1(t) \times x_2(t) = 0 \times 2 = 0$

$-3 < t < 3$ amplitude of $z(t) = x_1(t) \times x_2(t) = 1 \times 2 = 2$

$3 < t < 10$ amplitude of $z(t) = x_1(t) \times x_2(t) = 0 \times 2 = 0$

The following operations can be performed with time:

Time Shifting

$x(t \pm t_0)$ is time shifted version of the signal $x(t)$.

$x(t + t_0) \rightarrow$ negative shift

$x(t - t_0) \rightarrow$ positive shift

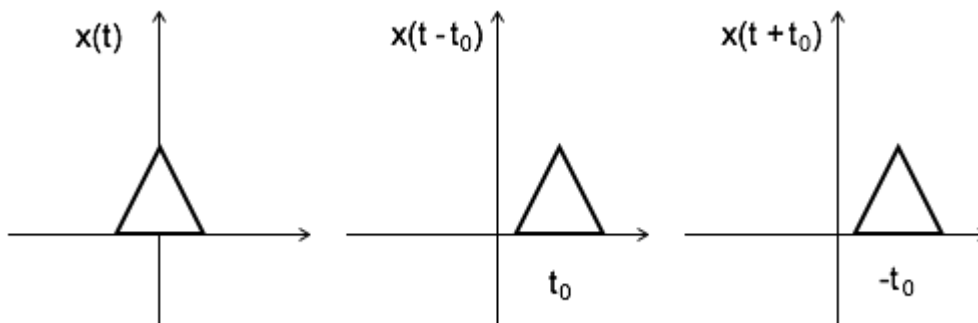

Time Scaling

$x(At)$ is time scaled version of the signal $x(t)$, where A is always positive.

$|A| > 1 \rightarrow$ Compression of the signal

$|A| < 1 \rightarrow$ Expansion of the signal

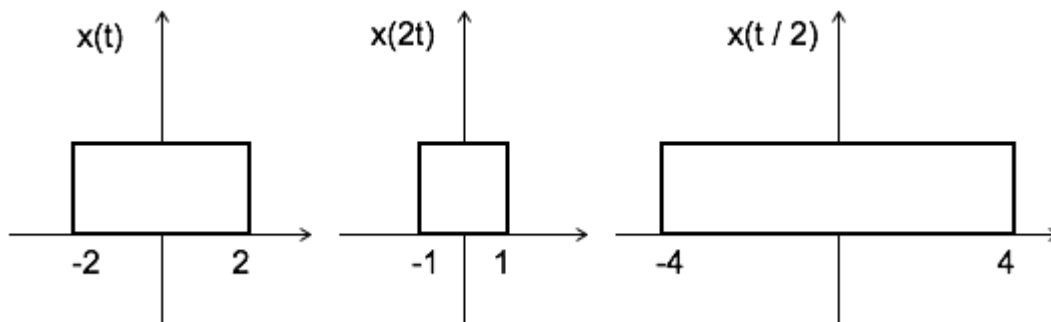

Note: $u(at) = ut$ time scaling is not applicable for unit step function.

Time Reversal

$x(-t)$ is the time reversal of the signal $x(t)$.

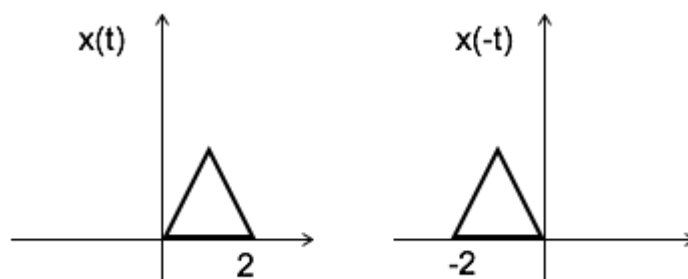

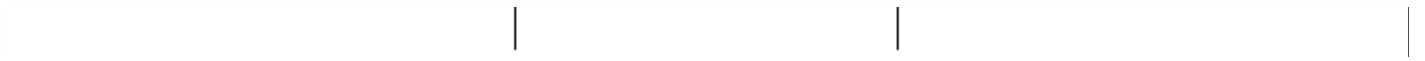

FOURIER SERIES

Jean Baptiste Joseph Fourier, a French mathematician and a physicist; was born in Auxerre, France. He initialized Fourier series, Fourier transforms and their applications to problems of heat transfer and vibrations. The Fourier series, Fourier transforms and Fourier's Law are named in his honour.



Jean Baptiste Joseph Fourier 21 March 1768– 16 May 1830

Fourier series

To represent any periodic signal $x(t)$, Fourier developed an expression called Fourier series. This is in terms of an infinite sum of sines and cosines or exponentials. Fourier series uses orthogonality condition.

Fourier Series Representation of Continuous Time Periodic Signals

A signal is said to be periodic if it satisfies the condition $x(t) = x(t + T)$ or $x(n) = x(n + N)$.

Where T = fundamental time period,

$$\omega_0 = \text{fundamental frequency} = 2\pi/T$$

There are two basic periodic signals:

$$x(t) = \cos \omega_0 t \text{ sinusoidal \&}$$

$$x(t) = e^{j\omega_0 t} \text{ complex exponential}$$

These two signals are periodic with period $T = 2\pi/\omega_0$.

A set of harmonically related complex exponentials can be represented as $\{\phi_k(t)\}$

$$\phi_k(t) = \{e^{jk\omega_0 t}\} = \{e^{jk(\frac{2\pi}{T})t}\} \text{ where } k = 0 \pm 1, \pm 2, \dots, n \dots (1)$$

All these signals are periodic with period T

According to orthogonal signal space approximation of a function $x(t)$ with n , mutually orthogonal functions is given by

$$x(t) = \sum_{k=-\infty}^{\infty} a_k e^{jk\omega_0 t} \dots (2)$$

$$= \sum_{k=-\infty}^{\infty} a_k k e^{jk\omega_0 t}$$

Where a_k = Fourier coefficient = coefficient of approximation.

This signal $x(t)$ is also periodic with period T .

Equation 2 represents Fourier series representation of periodic signal $x(t)$.

The term $k = 0$ is constant.

The term $k = \pm 1$ having fundamental frequency ω_0 , is called as 1st harmonics.

The term $k = \pm 2$ having fundamental frequency $2\omega_0$, is called as 2nd harmonics, and so on...

The term $k = \pm n$ having fundamental frequency $n\omega_0$, is called as nth harmonics.

Deriving Fourier Coefficient

We know that $x(t) = \sum_{k=-\infty}^{\infty} a_k e^{jk\omega_0 t} \dots \dots (1)$

Multiply $e^{-jn\omega_0 t}$ on both sides. Then

$$x(t)e^{-jn\omega_0 t} = \sum_{k=-\infty}^{\infty} a_k e^{jk\omega_0 t} \cdot e^{-jn\omega_0 t}$$

Consider integral on both sides.

$$\begin{aligned} \int_0^T x(t)e^{jk\omega_0 t} dt &= \int_0^T \sum_{k=-\infty}^{\infty} a_k e^{jk\omega_0 t} \cdot e^{-jn\omega_0 t} dt \\ &= \int_0^T \sum_{k=-\infty}^{\infty} a_k e^{j(k-n)\omega_0 t} \cdot dt \\ \int_0^T x(t)e^{jk\omega_0 t} dt &= \sum_{k=-\infty}^{\infty} a_k \int_0^T e^{j(k-n)\omega_0 t} dt. \dots \dots (2) \end{aligned}$$

by Euler's formula,

$$\begin{aligned} \int_0^T e^{j(k-n)\omega_0 t} dt &= \int_0^T \cos(k-n)\omega_0 t dt + j \int_0^T \sin(k-n)\omega_0 t dt \\ \int_0^T e^{j(k-n)\omega_0 t} dt &= \begin{cases} T & k = n \\ 0 & k \neq n \end{cases} \end{aligned}$$

Hence in equation 2, the integral is zero for all values of k except at $k = n$. Put $k = n$ in equation 2.

$$\Rightarrow \int_0^T x(t) e^{-jn\omega_0 t} dt = a_n T$$

$$\Rightarrow a_n = \frac{1}{T} \int_0^T e^{-jn\omega_0 t} dt$$

Replace n by k.

$$\Rightarrow a_k = \frac{1}{T} \int_0^T e^{-jk\omega_0 t} dt$$

$$\therefore x(t) = \sum_{k=-\infty}^{\infty} a_k e^{j(k-n)\omega_0 t}$$

$$\text{where } a_k = \frac{1}{T} \int_0^T e^{-jk\omega_0 t} dt$$

FOURIER SERIES PROPERTIES

These are properties of Fourier series:

Linearity Property

If $x(t) \xleftrightarrow{\text{fourier series coefficient}} f_{xn}$ & $y(t) \xleftrightarrow{\text{fourier series coefficient}} f_{yn}$

then linearity property states that

$a x(t) + b y(t) \xleftrightarrow{\text{fourier series coefficient}} a f_{xn} + b f_{yn}$

Time Shifting Property

If $x(t) \xleftrightarrow{\text{fourier series coefficient}} f_{xn}$

then time shifting property states that

$x(t - t_0) \xleftrightarrow{\text{fourier series coefficient}} e^{-jn\omega_0 t_0} f_{xn}$

Frequency Shifting Property

If $x(t) \xleftrightarrow{\text{fourier series coefficient}} f_{xn}$

then frequency shifting property states that

$e^{jn\omega_0 t_0} \cdot x(t) \xleftrightarrow{\text{fourier series coefficient}} f_{x(n-n_0)}$

Time Reversal Property

If $x(t) \xleftrightarrow{\text{fourier series coefficient}} f_{xn}$

then time reversal property states that

If $x(-t) \xleftrightarrow{\text{fourier series coefficient}} f_{-xn}$

Time Scaling Property

If $x(t) \xleftrightarrow{\text{fourier series coefficient}} f_{xn}$

then time scaling property states that

If $x(at) \xleftrightarrow{\text{fourier series coefficient}} f_{xn}$

Time scaling property changes frequency components from ω_0 to $a\omega_0$.

Differentiation and Integration Properties

If $x(t) \xleftrightarrow{\text{fourier series coefficient}} f_{xn}$

then differentiation property states that

$$\text{If } \frac{dx(t)}{dt} \xleftrightarrow{\text{fourier series coefficient}} jn\omega_0 \cdot f_{xn}$$

& integration property states that

$$\text{If } \int x(t)dt \xleftrightarrow{\text{fourier series coefficient}} \frac{f_{xn}}{jn\omega_0}$$

Multiplication and Convolution Properties

$$\text{If } x(t) \xleftrightarrow{\text{fourier series coefficient}} f_{xn} \text{ \& } y(t) \xleftrightarrow{\text{fourier series coefficient}} f_{yn}$$

then multiplication property states that

$$x(t) \cdot y(t) \xleftrightarrow{\text{fourier series coefficient}} T f_{xn} * f_{yn}$$

& convolution property states that

$$x(t) * y(t) \xleftrightarrow{\text{fourier series coefficient}} T f_{xn} \cdot f_{yn}$$

Conjugate and Conjugate Symmetry Properties

$$\text{If } x(t) \xleftrightarrow{\text{fourier series coefficient}} f_{xn}$$

Then conjugate property states that

$$x^*(t) \xleftrightarrow{\text{fourier series coefficient}} f^*_{xn}$$

Conjugate symmetry property for real valued time signal states that

$$f^*_{xn} = f_{-xn}$$

& Conjugate symmetry property for imaginary valued time signal states that

$$f^*_{xn} = -f_{-xn}$$

FOURIER SERIES TYPES

Trigonometric Fourier Series TFS

$\sin n\omega_0 t$ and $\sin m\omega_0 t$ are orthogonal over the interval $(t_0, t_0 + \frac{2\pi}{\omega_0})$. So $\sin \omega_0 t, \sin 2\omega_0 t$ forms an orthogonal set. This set is not complete without $\{\cos n\omega_0 t\}$ because this cosine set is also orthogonal to sine set. So to complete this set we must include both cosine and sine terms. Now the complete orthogonal set contains all cosine and sine terms i.e. $\{\sin n\omega_0 t, \cos n\omega_0 t\}$ where $n=0, 1, 2, \dots$

\therefore Any function $x(t)$ in the interval $(t_0, t_0 + \frac{2\pi}{\omega_0})$ can be represented as

$$\begin{aligned} x(t) &= a_0 \cos 0\omega_0 t + a_1 \cos 1\omega_0 t + a_2 \cos 2\omega_0 t + \dots + a_n \cos n\omega_0 t + \dots \\ &\quad + b_0 \sin 0\omega_0 t + b_1 \sin 1\omega_0 t + \dots + b_n \sin n\omega_0 t + \dots \\ &= a_0 + a_1 \cos 1\omega_0 t + a_2 \cos 2\omega_0 t + \dots + a_n \cos n\omega_0 t + \dots \\ &\quad + b_1 \sin 1\omega_0 t + \dots + b_n \sin n\omega_0 t + \dots \end{aligned}$$

$$\therefore x(t) = a_0 + \sum_{n=1}^{\infty} (a_n \cos n\omega_0 t + b_n \sin n\omega_0 t) \quad (t_0 < t < t_0 + T)$$

The above equation represents trigonometric Fourier series representation of $x(t)$.

$$\text{Where } a_0 = \frac{\int_{t_0}^{t_0+T} x(t) \cdot 1 dt}{\int_{t_0}^{t_0+T} 1^2 dt} = \frac{1}{T} \cdot \int_{t_0}^{t_0+T} x(t) dt$$

$$a_n = \frac{\int_{t_0}^{t_0+T} x(t) \cdot \cos n\omega_0 t dt}{\int_{t_0}^{t_0+T} \cos^2 n\omega_0 t dt}$$

$$b_n = \frac{\int_{t_0}^{t_0+T} x(t) \cdot \sin n\omega_0 t dt}{\int_{t_0}^{t_0+T} \sin^2 n\omega_0 t dt}$$

$$\text{Here } \int_{t_0}^{t_0+T} \cos^2 n\omega_0 t dt = \int_{t_0}^{t_0+T} \sin^2 n\omega_0 t dt = \frac{T}{2}$$

$$\therefore a_n = \frac{2}{T} \cdot \int_{t_0}^{t_0+T} x(t) \cdot \cos n\omega_0 t dt$$

$$b_n = \frac{2}{T} \cdot \int_{t_0}^{t_0+T} x(t) \cdot \sin n\omega_0 t dt$$

Exponential Fourier Series EFS

Consider a set of complex exponential functions $\{e^{jn\omega_0 t}\}$ ($n = 0, \pm 1, \pm 2, \dots$) which is orthogonal over the interval $(t_0, t_0 + T)$. Where $T = \frac{2\pi}{\omega_0}$. This is a complete set so it is possible to represent any function $f(t)$ as shown below

$$\begin{aligned} f(t) &= F_0 + F_1 e^{j\omega_0 t} + F_2 e^{j2\omega_0 t} + \dots + F_n e^{jn\omega_0 t} + \dots \\ &\quad F_{-1} e^{-j\omega_0 t} + F_{-2} e^{-j2\omega_0 t} + \dots + F_{-n} e^{-jn\omega_0 t} + \dots \end{aligned}$$

$$\therefore f(t) = \sum_{n=-\infty}^{\infty} F_n e^{jn\omega_0 t} \quad (t_0 < t < t_0 + T) \dots \dots (1)$$

Equation 1 represents exponential Fourier series representation of a signal $f(t)$ over the interval $(t_0, t_0 + T)$. The Fourier coefficient is given as

$$\begin{aligned} F_n &= \frac{\int_{t_0}^{t_0+T} f(t) (e^{jn\omega_0 t})^* dt}{\int_{t_0}^{t_0+T} e^{jn\omega_0 t} (e^{jn\omega_0 t})^* dt} \\ &= \frac{\int_{t_0}^{t_0+T} f(t) e^{-jn\omega_0 t} dt}{\int_{t_0}^{t_0+T} e^{-jn\omega_0 t} e^{jn\omega_0 t} dt} \\ &= \frac{\int_{t_0}^{t_0+T} f(t) e^{-jn\omega_0 t} dt}{\int_{t_0}^{t_0+T} 1 dt} = \frac{1}{T} \int_{t_0}^{t_0+T} f(t) e^{-jn\omega_0 t} dt \end{aligned}$$

$$\therefore F_n = \frac{1}{T} \int_{t_0}^{t_0+T} f(t) e^{-jn\omega_0 t} dt$$

Relation Between Trigonometric and Exponential Fourier Series

Consider a periodic signal $x(t)$, the TFS & EFS representations are given below respectively

$$x(t) = a_0 + \sum_{n=1}^{\infty} (a_n \cos n\omega_0 t + b_n \sin n\omega_0 t) \dots \dots (1)$$

$$x(t) = \sum_{n=-\infty}^{\infty} F_n e^{jn\omega_0 t}$$

$$= F_0 + F_1 e^{j\omega_0 t} + F_2 e^{j2\omega_0 t} + \dots + F_n e^{jn\omega_0 t} + \dots$$

$$F_{-1} e^{-j\omega_0 t} + F_{-2} e^{-j2\omega_0 t} + \dots + F_{-n} e^{-jn\omega_0 t} + \dots$$

$$= F_0 + F_1 (\cos \omega_0 t + j \sin \omega_0 t) + F_2 (\cos 2\omega_0 t + j \sin 2\omega_0 t) + \dots + F_n (\cos n\omega_0 t + j \sin n\omega_0 t) + \dots + F_{-1} (\cos \omega_0 t - j \sin \omega_0 t) + F_{-2} (\cos 2\omega_0 t - j \sin 2\omega_0 t) + \dots + F_{-n} (\cos n\omega_0 t - j \sin n\omega_0 t) + \dots$$

$$= F_0 + (F_1 + F_{-1}) \cos \omega_0 t + (F_2 + F_{-2}) \cos 2\omega_0 t + \dots + j(F_1 - F_{-1}) \sin \omega_0 t + j(F_2 - F_{-2}) \sin 2\omega_0 t + \dots$$

$$\therefore x(t) = F_0 + \sum_{n=1}^{\infty} ((F_n + F_{-n}) \cos n\omega_0 t + j(F_n - F_{-n}) \sin n\omega_0 t) \dots \dots (2)$$

Compare equation 1 and 2.

$$a_0 = F_0$$

$$a_n = F_n + F_{-n}$$

$$b_n = j(F_n - F_{-n})$$

Similarly,

$$F_n = \frac{1}{2}(a_n - jb_n)$$

$$F_{-n} = \frac{1}{2}(a_n + jb_n)$$

UNIT 2 - FOURIER TRANSFORMS

The main drawback of Fourier series is, it is only applicable to periodic signals. There are some naturally produced signals such as nonperiodic or aperiodic, which we cannot represent using Fourier series. To overcome this shortcoming, Fourier developed a mathematical model to transform signals between time *orspatial* domain to frequency domain & vice versa, which is called 'Fourier transform'.

Fourier transform has many applications in physics and engineering such as analysis of LTI systems, RADAR, astronomy, signal processing etc.

Deriving Fourier transform from Fourier series

Consider a periodic signal $f(t)$ with period T . The complex Fourier series representation of $f(t)$ is given as

$$\begin{aligned} f(t) &= \sum_{k=-\infty}^{\infty} a_k e^{jk\omega_0 t} \\ &= \sum_{k=-\infty}^{\infty} a_k e^{j\frac{2\pi}{T_0} kt} \dots\dots (1) \end{aligned}$$

Let $\frac{1}{T_0} = \Delta f$, then equation 1 becomes

$$f(t) = \sum_{k=-\infty}^{\infty} a_k e^{j2\pi k \Delta f t} \dots\dots (2)$$

but you know that

$$a_k = \frac{1}{T_0} \int_{t_0}^{t_0+T} f(t) e^{-jk\omega_0 t} dt$$

Substitute in equation 2.

$$2 \Rightarrow f(t) = \sum_{k=-\infty}^{\infty} \frac{1}{T_0} \int_{t_0}^{t_0+T} f(t) e^{-jk\omega_0 t} dt e^{j2\pi k \Delta f t}$$

$$\text{Let } t_0 = \frac{T}{2}$$

$$= \sum_{k=-\infty}^{\infty} \left[\int_{\frac{-T}{2}}^{\frac{T}{2}} f(t) e^{-j2\pi k \Delta f t} dt \right] e^{j2\pi k \Delta f t} \cdot \Delta f$$

In the limit as $T \rightarrow \infty$, Δf approaches differential df , $k\Delta f$ becomes a continuous variable f , and summation becomes integration

$$\begin{aligned} f(t) &= \lim_{T \rightarrow \infty} \left\{ \sum_{k=-\infty}^{\infty} \left[\int_{\frac{-T}{2}}^{\frac{T}{2}} f(t) e^{-j2\pi k \Delta f t} dt \right] e^{j2\pi k \Delta f t} \cdot \Delta f \right\} \\ &= \int_{-\infty}^{\infty} \left[\int_{-\infty}^{\infty} f(t) e^{-j2\pi f t} dt \right] e^{j2\pi f t} df \end{aligned}$$

$$f(t) = \int_{-\infty}^{\infty} F[\omega] e^{j\omega t} d\omega$$

Where $F[\omega] = [\int_{-\infty}^{\infty} f(t) e^{-j\omega t} dt]$

Fourier transform of a signal

$$f(t) = F[\omega] = [\int_{-\infty}^{\infty} f(t) e^{-j\omega t} dt]$$

Inverse Fourier Transform is

$$f(t) = \int_{-\infty}^{\infty} F[\omega] e^{j\omega t} d\omega$$

Fourier Transform of Basic Functions

Let us go through Fourier Transform of basic functions:

FT of GATE Function

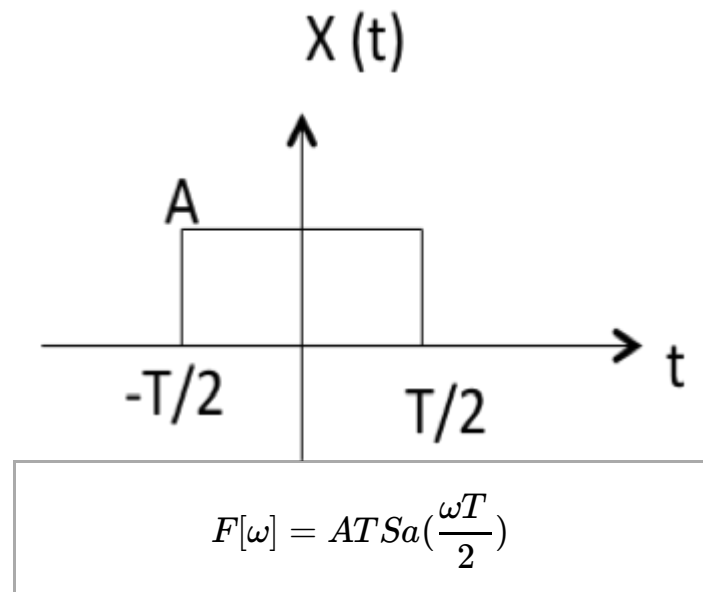

FT of Impulse Function

$$\begin{aligned}
 FT[\omega(t)] &= [\int_{-\infty}^{\infty} \delta(t) e^{-j\omega t} dt] \\
 &= e^{-j\omega t} \Big|_{t=0} \\
 &= e^0 = 1
 \end{aligned}$$

$\therefore \delta(\omega) = 1$

FT of Unit Step Function:

$$U(\omega) = \pi\delta(\omega) + 1/j\omega$$

FT of Exponentials

$$e^{-at}u(t) \xleftrightarrow{\text{F.T}} 1/(a + j\omega)$$

$$e^{-at}u(t) \xleftrightarrow{\text{F.T}} 1/(a + j\omega)$$

$$e^{-a|t|} \xleftrightarrow{\text{F.T}} \frac{2a}{a^2 + \omega^2}$$

$$e^{j\omega_0 t} \xleftrightarrow{\text{F.T}} \delta(\omega - \omega_0)$$

FT of Signum Function

$$\text{sgn}(t) \xleftrightarrow{\text{F.T}} \frac{2}{j\omega}$$

Conditions for Existence of Fourier Transform

Any function $f(t)$ can be represented by using Fourier transform only when the function satisfies Dirichlet's conditions. i.e.

- The function $f(t)$ has finite number of maxima and minima.
- There must be finite number of discontinuities in the signal $f(t)$, in the given interval of time.
- It must be absolutely integrable in the given interval of time i.e.

$$\int_{-\infty}^{\infty} |f(t)| dt < \infty$$

—

FOURIER TRANSFORMS PROPERTIES

Here are the properties of Fourier Transform:

Linearity Property

$$\text{If } x(t) \xleftrightarrow{\text{F.T}} X(\omega)$$

$$\& y(t) \xleftrightarrow{\text{F.T}} Y(\omega)$$

Then linearity property states that

$$ax(t) + by(t) \xleftrightarrow{\text{F.T}} aX(\omega) + bY(\omega)$$

Time Shifting Property

$$\text{If } x(t) \xleftrightarrow{\text{F.T}} X(\omega)$$

Then Time shifting property states that

$$x(t - t_0) \xleftrightarrow{\text{F.T}} e^{-j\omega t_0} X(\omega)$$

Frequency Shifting Property

$$\text{If } x(t) \xleftrightarrow{\text{F.T}} X(\omega)$$

Then frequency shifting property states that

$$e^{j\omega_0 t} \cdot x(t) \xleftrightarrow{\text{F.T}} X(\omega - \omega_0)$$

Time Reversal Property

$$\text{If } x(t) \xleftrightarrow{\text{F.T}} X(\omega)$$

Then Time reversal property states that

$$x(-t) \xleftrightarrow{\text{F.T}} X(-\omega)$$

Time Scaling Property

$$\text{If } x(t) \xleftrightarrow{\text{F.T}} X(\omega)$$

Then Time scaling property states that

$$x(at) \xleftrightarrow{\text{F.T}} \frac{1}{|a|} X\left(\frac{\omega}{a}\right)$$

Differentiation and Integration Properties

$$\text{If } x(t) \xleftrightarrow{\text{F.T}} X(\omega)$$

Then Differentiation property states that

$$\frac{dx(t)}{dt} \xleftrightarrow{\text{F.T}} j\omega \cdot X(\omega)$$

$$\frac{d^n x(t)}{dt^n} \xleftrightarrow{\text{F.T}} (j\omega)^n \cdot X(\omega)$$

and integration property states that

$$\int x(t) dt \xleftrightarrow{\text{F.T}} \frac{1}{j\omega} X(\omega)$$

$$\iint \dots \int x(t) dt \xleftrightarrow{\text{F.T}} \frac{1}{(j\omega)^n} X(\omega)$$

Multiplication and Convolution Properties

$$\text{If } x(t) \xleftrightarrow{\text{F.T}} X(\omega)$$

$$\& \text{ } y(t) \xleftrightarrow{\text{F.T}} Y(\omega)$$

Then multiplication property states that

$$x(t) \cdot y(t) \xleftrightarrow{\text{F.T}} X(\omega) * Y(\omega)$$

and convolution property states that

$$x(t) * y(t) \xleftrightarrow{\text{F.T}} \frac{1}{2\pi} X(\omega) \cdot Y(\omega)$$

SIGNALS SAMPLING THEOREM

Statement: A continuous time signal can be represented in its samples and can be recovered back when sampling frequency f_s is greater than or equal to the twice the highest frequency component of message signal. i. e.

$$f_s \leq 2f_m.$$

Proof: Consider a continuous time signal $x(t)$. The spectrum of $x(t)$ is a band limited to f_m Hz i.e. the spectrum of $x(t)$ is zero for $|\omega| > \omega_m$.

Sampling of input signal $x(t)$ can be obtained by multiplying $x(t)$ with an impulse train $\delta(t)$ of period T_s . The output of multiplier is a discrete signal called sampled signal which is represented with $y(t)$ in the following diagrams:

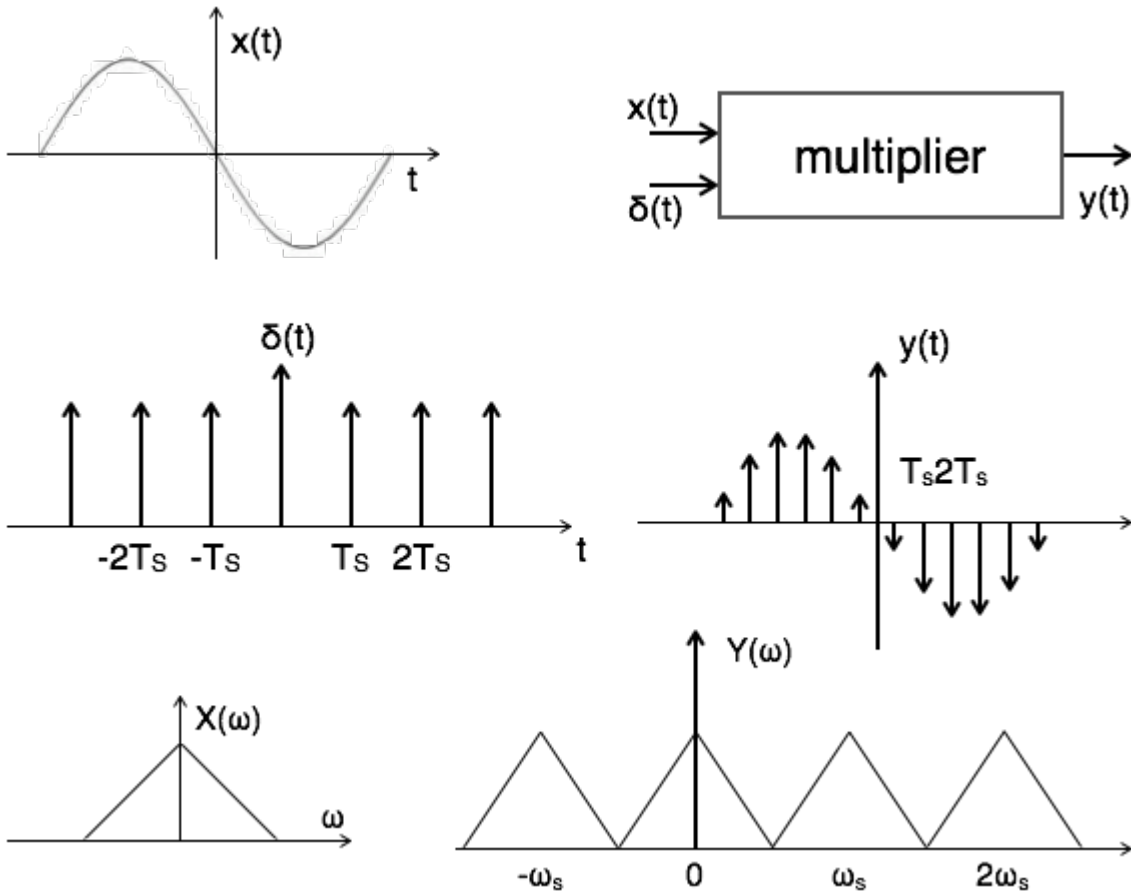

Here, you can observe that the sampled signal takes the period of impulse. The process of sampling can be explained by the following mathematical expression:

$$\text{Sampled signal } y(t) = x(t) \cdot \delta(t) \dots \dots (1)$$

The trigonometric Fourier series representation of $\delta(t)$ is given by

$$\delta(t) = a_0 + \sum_{n=1}^{\infty} (a_n \cos n\omega_s t + b_n \sin n\omega_s t) \dots \dots (2)$$

Where $a_0 = \frac{1}{T_s} \int_{-\frac{T_s}{2}}^{\frac{T_s}{2}} \delta(t) dt = \frac{1}{T_s} \delta(0) = \frac{1}{T_s}$

$$a_n = \frac{2}{T_s} \int_{-\frac{T_s}{2}}^{\frac{T_s}{2}} \delta(t) \cos n\omega_s t dt = \frac{2}{T_s} \delta(0) \cos n\omega_s 0 = \frac{2}{T_s}$$

$$b_n = \frac{2}{T_s} \int_{-\frac{T_s}{2}}^{\frac{T_s}{2}} \delta(t) \sin n\omega_s t dt = \frac{2}{T_s} \delta(0) \sin n\omega_s 0 = 0$$

Substitute above values in equation 2.

$$\therefore \delta(t) = \frac{1}{T_s} + \sum_{n=1}^{\infty} \left(\frac{2}{T_s} \cos n\omega_s t + 0 \right)$$

Substitute δt in equation 1.

$$\rightarrow y(t) = x(t) \cdot \delta(t)$$

$$= x(t) \left[\frac{1}{T_s} + \sum_{n=1}^{\infty} \left(\frac{2}{T_s} \cos n\omega_s t \right) \right]$$

$$= \frac{1}{T_s} [x(t) + 2 \sum_{n=1}^{\infty} (\cos n\omega_s t) x(t)]$$

$$y(t) = \frac{1}{T_s} [x(t) + 2 \cos \omega_s t \cdot x(t) + 2 \cos 2\omega_s t \cdot x(t) + 2 \cos 3\omega_s t \cdot x(t) \dots \dots]$$

Take Fourier transform on both sides.

$$Y(\omega) = \frac{1}{T_s} [X(\omega) + X(\omega - \omega_s) + X(\omega + \omega_s) + X(\omega - 2\omega_s) + X(\omega + 2\omega_s) + \dots]$$

$$\therefore Y(\omega) = \frac{1}{T_s} \sum_{n=-\infty}^{\infty} X(\omega - n\omega_s) \quad \text{where } n = 0, \pm 1, \pm 2, \dots$$

To reconstruct $x(t)$, you must recover input signal spectrum $X(\omega)$ from sampled signal spectrum $Y(\omega)$, which is possible when there is no overlapping between the cycles of $Y(\omega)$.

Possibility of sampled frequency spectrum with different conditions is given by the following diagrams:

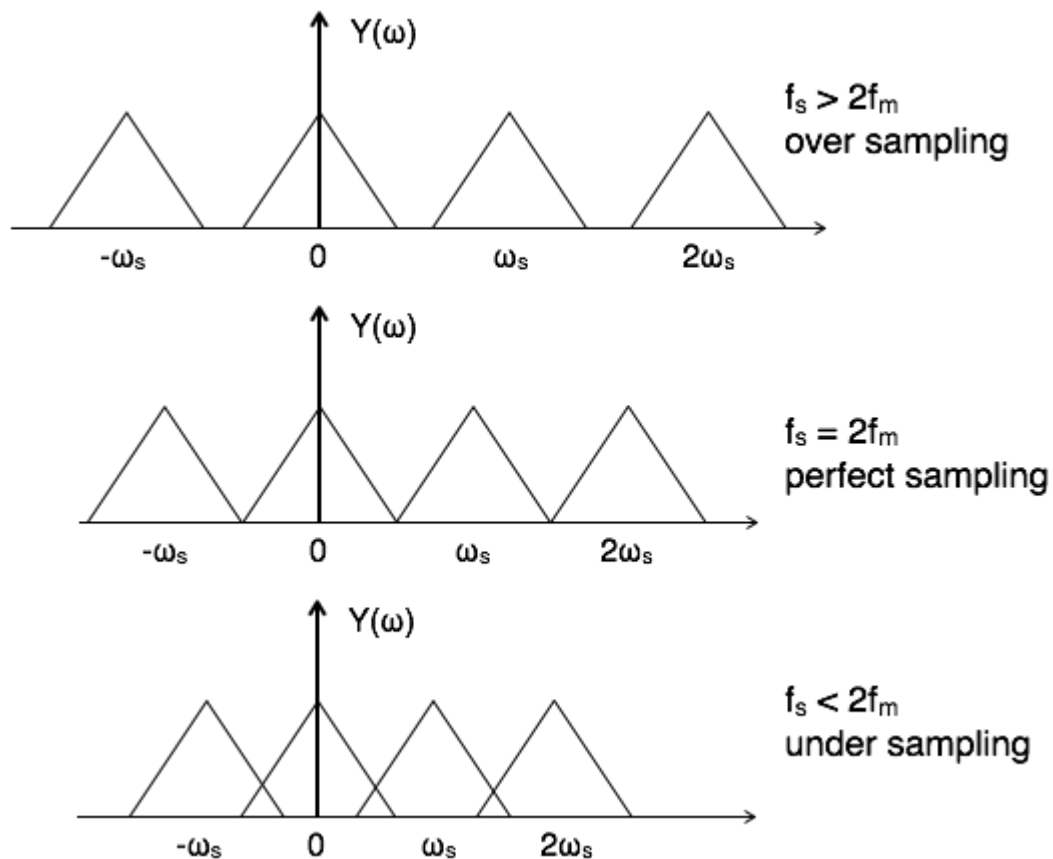

Aliasing Effect

The overlapped region in case of under sampling represents aliasing effect, which can be

removed by

- considering $f_s > 2f_m$
- By using anti aliasing filters.

SIGNALS SAMPLING TECHNIQUES

There are three types of sampling techniques:

- Impulse sampling.
- Natural sampling.
- Flat Top sampling.

Impulse Sampling

Impulse sampling can be performed by multiplying input signal $x(t)$ with impulse train $\sum_{n=-\infty}^{\infty} \delta(t - nT)$ of period 'T'. Here, the amplitude of impulse changes with respect to amplitude of input signal $x(t)$. The output of sampler is given by

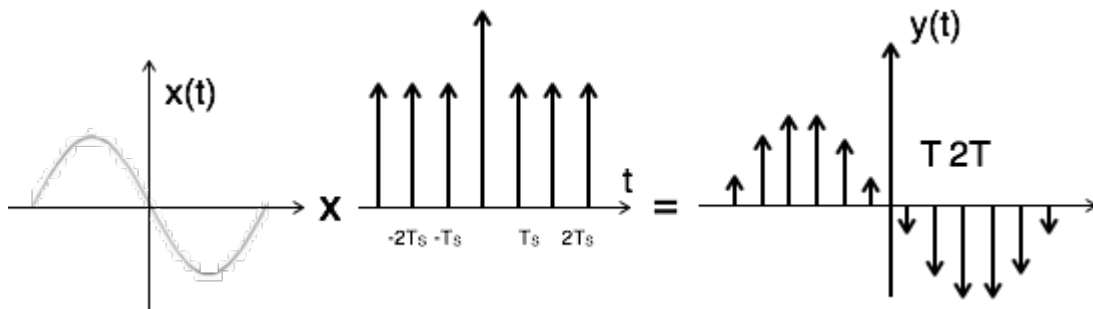

$$y(t) = x(t) \times \text{impulse train}$$

$$= x(t) \times \sum_{n=-\infty}^{\infty} \delta(t - nT)$$

$$y(t) = y_s(t) = \sum_{n=-\infty}^{\infty} x(nT) \delta(t - nT) \dots \dots 1$$

To get the spectrum of sampled signal, consider Fourier transform of equation 1 on both sides

$$Y(\omega) = \frac{1}{T} \sum_{n=-\infty}^{\infty} X(\omega - n\omega_s)$$

This is called ideal sampling or impulse sampling. You cannot use this practically because pulse width cannot be zero and the generation of impulse train is not possible practically.

Natural Sampling

Natural sampling is similar to impulse sampling, except the impulse train is replaced by pulse train of period T. i.e. you multiply input signal $x(t)$ to pulse train $\sum_{n=-\infty}^{\infty} P(t - nT)$ as shown below

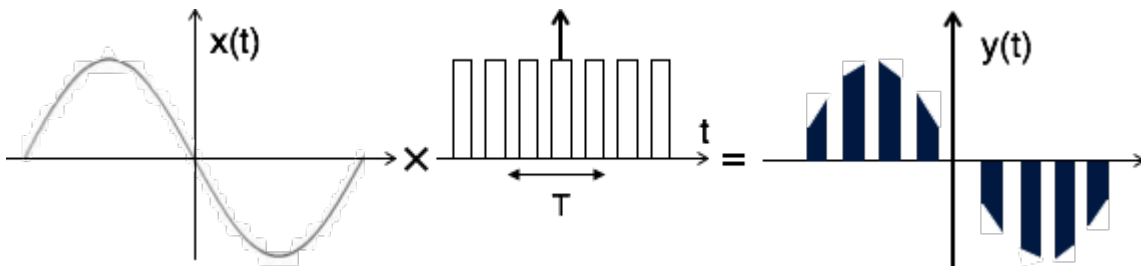

The output of sampler is

$$y(t) = x(t) \times \text{pulse train}$$

$$= x(t) \times p(t)$$

$$= x(t) \times \sum_{n=-\infty}^{\infty} P(t - nT) \dots \dots (1)$$

The exponential Fourier series representation of pt can be given as

$$p(t) = \sum_{n=-\infty}^{\infty} F_n e^{jn\omega_s t} \dots \dots (2)$$

$$= \sum_{n=-\infty}^{\infty} F_n e^{j2\pi n f_s t}$$

Where $F_n = \frac{1}{T} \int_{-\frac{T}{2}}^{\frac{T}{2}} p(t) e^{-jn\omega_s t} dt$

$$= \frac{1}{TP}(n\omega_s)$$

Substitute F_n value in equation 2

$$\therefore p(t) = \sum_{n=-\infty}^{\infty} \frac{1}{T} P(n\omega_s) e^{jn\omega_s t}$$

$$= \frac{1}{T} \sum_{n=-\infty}^{\infty} P(n\omega_s) e^{jn\omega_s t}$$

Substitute pt in equation 1

$$y(t) = x(t) \times p(t)$$

$$= x(t) \times \frac{1}{T} \sum_{n=-\infty}^{\infty} P(n\omega_s) e^{jn\omega_s t}$$

$$y(t) = \frac{1}{T} \sum_{n=-\infty}^{\infty} P(n\omega_s) x(t) e^{jn\omega_s t}$$

To get the spectrum of sampled signal, consider the Fourier transform on both sides.

$$F.T[y(t)] = F.T\left[\frac{1}{T} \sum_{n=-\infty}^{\infty} P(n\omega_s) x(t) e^{jn\omega_s t}\right]$$

$$= \frac{1}{T} \sum_{n=-\infty}^{\infty} P(n\omega_s) F.T[x(t) e^{jn\omega_s t}]$$

According to frequency shifting property

$$F.T[x(t) e^{jn\omega_s t}] = X[\omega - n\omega_s]$$

$$\therefore Y[\omega] = \frac{1}{T} \sum_{n=-\infty}^{\infty} P(n\omega_s) X[\omega - n\omega_s]$$

Flat Top Sampling

During transmission, noise is introduced at top of the transmission pulse which can be easily removed if the pulse is in the form of flat top. Here, the top of the samples are flat i.e. they have constant amplitude. Hence, it is called as flat top sampling or practical sampling. Flat top sampling makes use of sample and hold circuit.

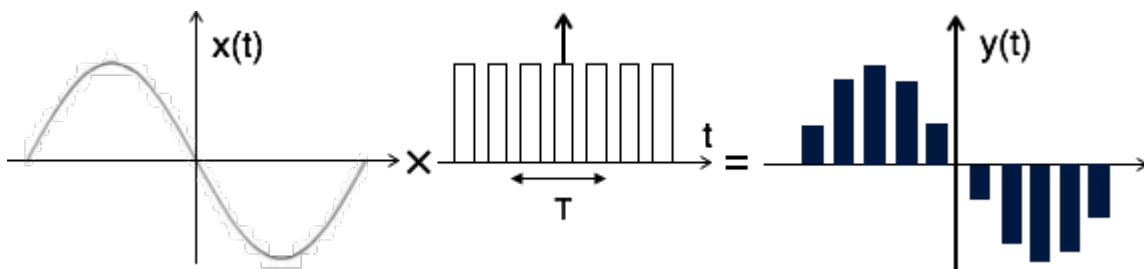

Theoretically, the sampled signal can be obtained by convolution of rectangular pulse pt with ideally sampled signal say $y_\delta t$ as shown in the diagram:

$$\text{i.e. } y(t) = p(t) \times y_{\delta}(t) \dots \dots (1)$$

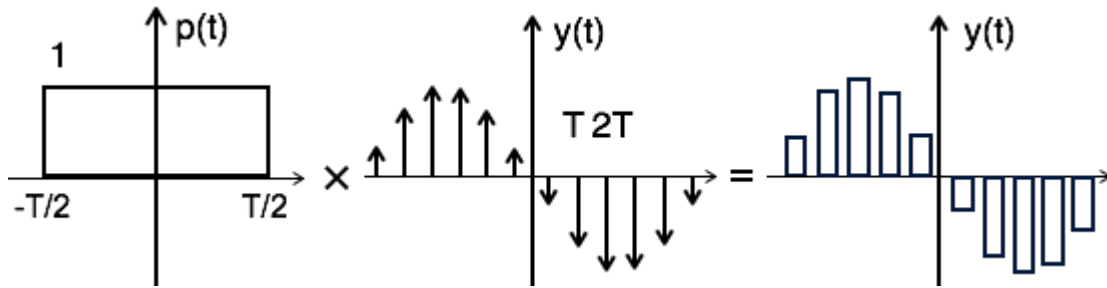

To get the sampled spectrum, consider Fourier transform on both sides for equation 1

$$Y[\omega] = F.T [P(t) \times y_{\delta}(t)]$$

By the knowledge of convolution property,

$$Y[\omega] = P(\omega) Y_{\delta}(\omega)$$

$$\text{Here } P(\omega) = T Sa\left(\frac{\omega T}{2}\right) = 2 \sin \omega T / \omega$$

Nyquist Rate

It is the minimum sampling rate at which signal can be converted into samples and can be recovered back without distortion.

$$\text{Nyquist rate } f_N = 2f_m \text{ hz}$$

$$\text{Nyquist interval} = \frac{1}{f_N} = \frac{1}{2f_m} \text{ seconds.}$$

Samplings of Band Pass Signals

In case of band pass signals, the spectrum of band pass signal $X[\omega] = 0$ for the frequencies outside the range $f_1 \leq f \leq f_2$. The frequency f_1 is always greater than zero. Plus, there is no aliasing effect when $f_s > 2f_2$. But it has two disadvantages:

- The sampling rate is large in proportion with f_2 . This has practical limitations.
- The sampled signal spectrum has spectral gaps.

To overcome this, the band pass theorem states that the input signal $x(t)$ can be converted into its samples and can be recovered back without distortion when sampling frequency $f_s < 2f_2$.

Also,

$$f_s = \frac{1}{T} = \frac{2f_2}{m}$$

Where m is the largest integer $< \frac{f_2}{B}$

and B is the bandwidth of the signal. If $f_2 = KB$, then

$$f_s = \frac{1}{T} = \frac{2KB}{m}$$

For band pass signals of bandwidth $2f_m$ and the minimum sampling rate $f_s = 2B = 4f_m$,

the spectrum of sampled signal is given by $Y[\omega] = \frac{1}{T} \sum_{n=-\infty}^{\infty} X[\omega - 2nB]$

UNIT 3 - SIGNAL TRANSMISSION THROUGH LTI SYSTEM

Systems are classified into the following categories:

- Liner and Non-liner Systems
- Time Variant and Time Invariant Systems
- Liner Time variant and Liner Time invariant systems
- Static and Dynamic Systems
- Causal and Non-causal Systems
- Invertible and Non-Invertible Systems
- Stable and Unstable Systems

Liner and Non-liner Systems

A system is said to be linear when it satisfies superposition and homogenate principles. Consider two systems with inputs as x_1t , x_2t , and outputs as y_1t , y_2t respectively. Then, according to the superposition and homogenate principles,

$$T [a_1 x_1t + a_2 x_2t] = a_1 T[x_1t] + a_2 T[x_2t]$$

$$\therefore, T [a_1 x_1t + a_2 x_2t] = a_1 y_1t + a_2 y_2t$$

From the above expression, is clear that response of overall system is equal to response of individual system.

Example:

$$t = x^2t$$

Solution:

$$y_1 t = T[x_1t] = x_1^2t$$

$$y_2 t = T[x_2t] = x_2^2t$$

$$T [a_1 x_1t + a_2 x_2t] = [a_1 x_1t + a_2 x_2t]^2$$

Which is not equal to $a_1 y_1t + a_2 y_2t$. Hence the system is said to be non linear.

Time Variant and Time Invariant Systems

A system is said to be time variant if its input and output characteristics vary with time. Otherwise, the system is considered as time invariant.

The condition for time invariant system is:

$$y n, t = y n - t$$

The condition for time variant system is:

$$y n, t \neq y n - t$$

Where $y n, t = T[xn - t]$ = input change

$$y n - t = \text{output change}$$

Example:

$$y_n = x_{-n}$$

$$y_{n,t} = T[x_{n-t}] = x_{-n-t}$$

$$y_{n-t} = x_{-(n-t)} = x_{-n+t}$$

$\therefore y_{n,t} \neq y_{n-t}$. Hence, the system is time variant.

Liner Time variant *LTV* and Liner Time Invariant *LTI* Systems

If a system is both liner and time variant, then it is called liner time variant *LTV* system.

If a system is both liner and time Invariant then that system is called liner time invariant *LTI* system.

Static and Dynamic Systems

Static system is memory-less whereas dynamic system is a memory system.

Example 1: $y_t = 2x_t$

For present value $t=0$, the system output is $y_0 = 2x_0$. Here, the output is only dependent upon present input. Hence the system is memory less or static.

Example 2: $y_t = 2x_t + 3x_{t-3}$

For present value $t=0$, the system output is $y_0 = 2x_0 + 3x_{-3}$.

Here x_{-3} is past value for the present input for which the system requires memory to get this output. Hence, the system is a dynamic system.

Causal and Non-Causal Systems

A system is said to be causal if its output depends upon present and past inputs, and does not depend upon future input.

For non causal system, the output depends upon future inputs also.

Example 1: $y_n = 2x_n + 3x_{n-3}$

For present value $t=1$, the system output is $y_1 = 2x_1 + 3x_{-2}$.

Here, the system output only depends upon present and past inputs. Hence, the system is causal.

Example 2: $y_n = 2x_n + 3x_{n-3} + 6x_{n+3}$

For present value $t=1$, the system output is $y_1 = 2x_1 + 3x_{-2} + 6x_4$. Here, the system output depends upon future input. Hence the system is non-causal system.

Invertible and Non-Invertible systems

A system is said to be invertible if the input of the system appears at the output.

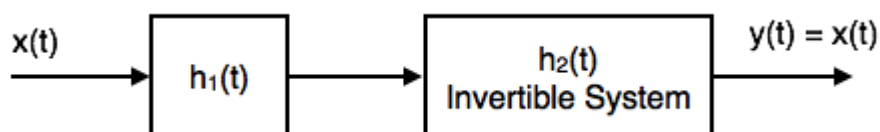

$$Y_S = X_S H_1(S) H_2(S)$$

$$= X_S H_1(S) \cdot \frac{1}{H_1(S)} \quad \text{Since } H_2(S) = 1/H_1(S)$$

$$\therefore Y_S = X_S$$

$$\rightarrow y(t) = x(t)$$

Hence, the system is invertible.

If $y(t) \neq x(t)$, then the system is said to be non-invertible.

Stable and Unstable Systems

The system is said to be stable only when the output is bounded for bounded input. For a bounded input, if the output is unbounded in the system then it is said to be unstable.

Note: For a bounded signal, amplitude is finite.

Example 1: $y(t) = x^2(t)$

Let the input is $u(t)$ *unit step bounded input* then the output $y(t) = u^2(t) = u(t) =$ bounded output.

Hence, the system is stable.

Example 2: $y(t) = \int x(t) dt$

Let the input is $u(t)$ *unit step bounded input* then the output $y(t) = \int u(t) dt =$ ramp signal *unbounded because amplitude of ramp is not finite it goes to infinity when $t \rightarrow \infty$* .

Hence, the system is unstable.

Convolution

Convolution is a mathematical operation used to express the relation between input and output of an LTI system. It relates input, output and impulse response of an LTI system as

$$y(t) = x(t) * h(t)$$

Where $y(t)$ = output of LTI

$x(t)$ = input of LTI

$h(t)$ = impulse response of LTI

There are two types of convolutions:

- Continuous convolution
- Discrete convolution

Continuous Convolution

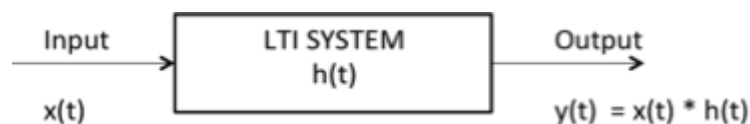

$$y(t) = x(t) * h(t)$$

$$= \int_{-\infty}^{\infty} x(\tau)h(t - \tau)d\tau$$

or

$$= \int_{-\infty}^{\infty} x(t - \tau)h(\tau)d\tau$$

Discrete Convolution

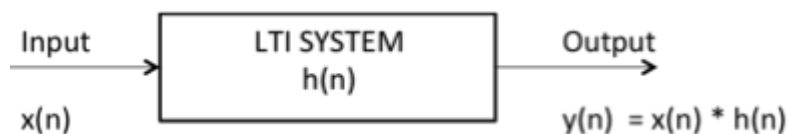

$$y(n) = x(n) * h(n)$$

$$= \sum_{k=-\infty}^{\infty} x(k)h(n - k)$$

or

$$= \sum_{k=-\infty}^{\infty} x(n - k)h(k)$$

By using convolution we can find zero state response of the system.

Deconvolution

Deconvolution is reverse process to convolution widely used in signal and image processing.

Properties of Convolution

Commutative Property

$$x_1(t) * x_2(t) = x_2(t) * x_1(t)$$

Distributive Property

$$x_1(t) * [x_2(t) + x_3(t)] = [x_1(t) * x_2(t)] + [x_1(t) * x_3(t)]$$

Associative Property

$$x_1(t) * [x_2(t) * x_3(t)] = [x_1(t) * x_2(t)] * x_3(t)$$

Shifting Property

$$x_1(t) * x_2(t) = y(t)$$

$$x_1(t) * x_2(t - t_0) = y(t - t_0)$$

$$x_1(t - t_0) * x_2(t) = y(t - t_0)$$

$$x_1(t - t_0) * x_2(t - t_1) = y(t - t_0 - t_1)$$

Convolution with Impulse

$$x_1(t) * \delta(t) = x(t)$$

$$x_1(t) * \delta(t - t_0) = x(t - t_0)$$

Convolution of Unit Steps

$$u(t) * u(t) = r(t)$$

$$u(t - T_1) * u(t - T_2) = r(t - T_1 - T_2)$$

$$u(n) * u(n) = [n + 1]u(n)$$

Scaling Property

$$\text{If } x(t) * h(t) = y(t)$$

$$\text{then } x(at) * h(at) = \frac{1}{|a|}y(at)$$

Differentiation of Output

$$\text{if } y(t) = x(t) * h(t)$$

$$\text{then } \frac{dy(t)}{dt} = \frac{dx(t)}{dt} * h(t)$$

or

$$\frac{dy(t)}{dt} = x(t) * \frac{dh(t)}{dt}$$

Note:

- Convolution of two causal sequences is causal.
- Convolution of two anti causal sequences is anti causal.
- Convolution of two unequal length rectangles results a trapezium.
- Convolution of two equal length rectangles results a triangle.

- A function convoluted itself is equal to integration of that function.

Example: You know that $u(t) * u(t) = r(t)$

According to above note, $u(t) * u(t) = \int u(t)dt = \int 1dt = t = r(t)$

Here, you get the result just by integrating $u(t)$.

Limits of Convolved Signal

If two signals are convoluted then the resulting convoluted signal has following range:

Sum of lower limits < t < sum of upper limits

Ex: find the range of convolution of signals given below

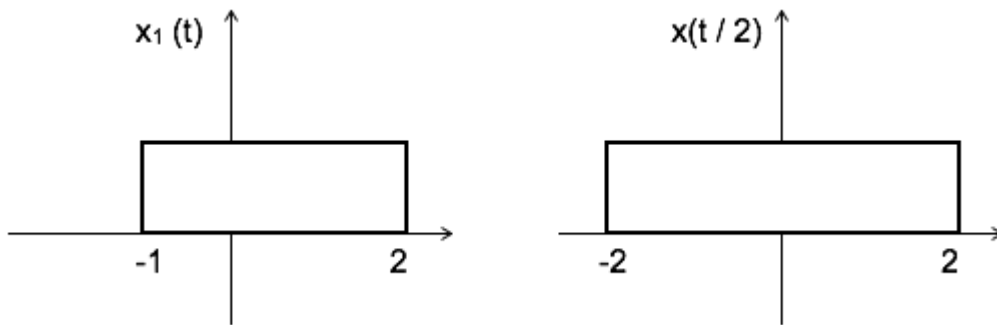

Here, we have two rectangles of unequal length to convolute, which results a trapezium.

The range of convoluted signal is:

Sum of lower limits < t < sum of upper limits

$$-1 + -2 < t < 2 + 2$$

$$-3 < t < 4$$

Hence the result is trapezium with period 7.

Area of Convolved Signal

The area under convoluted signal is given by $A_y = A_x A_h$

Where A_x = area under input signal

A_h = area under impulse response

A_y = area under output signal

Proof: $y(t) = \int_{-\infty}^{\infty} x(\tau)h(t - \tau)d\tau$

Take integration on both sides

$$\begin{aligned} \int y(t)dt &= \int \int_{-\infty}^{\infty} x(\tau)h(t - \tau)d\tau dt \\ &= \int x(\tau)d\tau \int_{-\infty}^{\infty} h(t - \tau)dt \end{aligned}$$

We know that area of any signal is the integration of that signal itself.

$$\therefore A_y = A_x A_h$$

DC Component

DC component of any signal is given by

$$\text{DC component} = \frac{\text{area of the signal}}{\text{period of the signal}}$$

Ex: what is the dc component of the resultant convoluted signal given below?

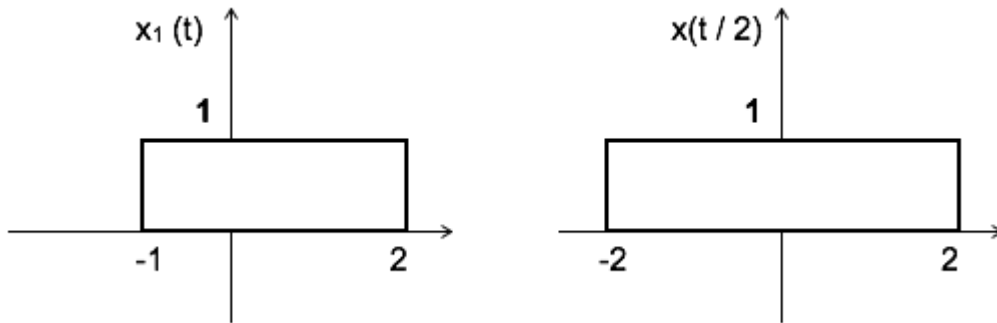

Here area of $x_1 t = \text{length} \times \text{breadth} = 1 \times 3 = 3$

area of $x_2 t = \text{length} \times \text{breadth} = 1 \times 4 = 4$

area of convoluted signal = area of $x_1 t \times$ area of $x_2 t$

$$= 3 \times 4 = 12$$

Duration of the convoluted signal = sum of lower limits $< t <$ sum of upper limits

$$= -1 + -2 < t < 2+2$$

$$= -3 < t < 4$$

Period=7

$$\therefore \text{Dc component of the convoluted signal} = \frac{\text{area of the signal}}{\text{period of the signal}}$$

$$\text{Dc component} = \frac{12}{7}$$

Discrete Convolution

Let us see how to calculate discrete convolution:

i. To calculate discrete linear convolution:

Convolute two sequences $x[n] = \{a,b,c\}$ & $h[n] = \{e,f,g\}$

	a	b	c
e	ea	eb	ec
f	fa	fb	fc
g	ga	gb	gc

Convoluted output = [ea, eb+fa, ec+fb+ga, fc+gb, gc]

Note: if any two sequences have m, n number of samples respectively, then the resulting convoluted sequence will have $[m+n-1]$ samples.

Example: Convolute two sequences $x[n] = \{1,2,3\}$ & $h[n] = \{-1,2,2\}$

x	1	2	3
-1	-1	-2	-3
2	2	4	6
2	2	4	6

Convolved output $y[n] = [-1, -2+2, -3+4+2, 6+4, 6]$
 $= [-1, 0, 3, 10, 6]$

Here $x[n]$ contains 3 samples and $h[n]$ is also having 3 samples so the resulting sequence having $3+3-1 = 5$ samples.

ii. To calculate periodic or circular convolution:

Periodic convolution is valid for discrete Fourier transform. To calculate periodic convolution all the samples must be real. Periodic or circular convolution is also called as fast convolution.

If two sequences of length m, n respectively are convoluted using circular convolution then resulting sequence having $\max[m, n]$ samples.

Ex: convolute two sequences $x[n] = \{1, 2, 3\}$ & $h[n] = \{-1, 2, 2\}$ using circular convolution

x	1	2	3
-1	-1	-2	-3
2	2	4	6
2	2	4	6

Normal Convolved output $y[n] = [-1, -2+2, -3+4+2, 6+4, 6]$.
 $= [-1, 0, 3, 10, 6]$

Here $x[n]$ contains 3 samples and $h[n]$ also has 3 samples. Hence the resulting sequence obtained by circular convolution must have $\max[3, 3] = 3$ samples.

Now to get periodic convolution result, 1st 3 samples [as the period is 3] of normal convolution is same next two samples are added to 1st samples as shown below:

$$\begin{array}{r}
 -1 \quad 0 \quad 3 \\
 + \quad 10 \quad 6 \\
 \hline
 9 \quad 6 \quad 3
 \end{array}$$

\therefore Circular convolution result $y[n] = [9 \quad 6 \quad 3]$

Correlation

Correlation is a measure of similarity between two signals. The general formula for correlation is

$$\int_{-\infty}^{\infty} x_1(t)x_2(t - \tau)dt$$

There are two types of correlation:

- Auto correlation
- Cros correlation

Auto Correlation Function

It is defined as correlation of a signal with itself. Auto correlation function is a measure of similarity between a signal & its time delayed version. It is represented with $R(\tau)$.

Consider a signals $x(t)$. The auto correlation function of $x(t)$ with its time delayed version is given by

$$\begin{aligned} R_{11}(\tau) = R(\tau) &= \int_{-\infty}^{\infty} x(t)x(t - \tau)dt \quad [+ve \text{ shift}] \\ &= \int_{-\infty}^{\infty} x(t)x(t + \tau)dt \quad [-ve \text{ shift}] \end{aligned}$$

Where τ = searching or scanning or delay parameter.

If the signal is complex then auto correlation function is given by

$$\begin{aligned} R_{11}(\tau) = R(\tau) &= \int_{-\infty}^{\infty} x(t)x^*(t - \tau)dt \quad [+ve \text{ shift}] \\ &= \int_{-\infty}^{\infty} x(t + \tau)x^*(t)dt \quad [-ve \text{ shift}] \end{aligned}$$

Properties of Auto-correlation Function of Energy Signal

- Auto correlation exhibits conjugate symmetry i.e. $R(\tau) = R^*(-\tau)$
- Auto correlation function of energy signal at origin i.e. at $\tau=0$ is equal to total energy of that signal, which is given as:

$$R(0) = E = \int_{-\infty}^{\infty} |x(t)|^2 dt$$

- Auto correlation function $\propto \frac{1}{\tau}$,
- Auto correlation function is maximum at $\tau=0$ i.e. $|R(\tau)| \leq R(0) \forall \tau$
- Auto correlation function and energy spectral densities are Fourier transform pairs. i.e.

$$F.T [R(\tau)] = \Psi(\omega)$$

$$\Psi(\omega) = \int_{-\infty}^{\infty} R(\tau)e^{-j\omega\tau} d\tau$$

- $R(\tau) = x(\tau) * x(-\tau)$

Auto Correlation Function of Power Signals

The auto correlation function of periodic power signal with period T is given by

$$R(\tau) = \lim_{T \rightarrow \infty} \frac{1}{T} \int_{-\frac{T}{2}}^{\frac{T}{2}} x(t)x^*(t - \tau)dt$$

Properties

- Auto correlation of power signal exhibits conjugate symmetry i.e. $R(\tau) = R^* (-\tau)$
- Auto correlation function of power signal at $\tau = 0$ *at origin* is equal to total power of that signal. i.e.

$$R(0) = \rho$$

- Auto correlation function of power signal $\propto \frac{1}{\tau}$,
- Auto correlation function of power signal is maximum at $\tau = 0$ i.e.,

$$|R(\tau)| \leq R(0) \forall \tau$$

- Auto correlation function and power spectral densities are Fourier transform pairs. i.e.,

$$F.T[R(\tau)] = s(\omega)$$

$$s(\omega) = \int_{-\infty}^{\infty} R(\tau) e^{-j\omega\tau} d\tau$$

- $R(\tau) = x(\tau) * x(-\tau)$

Density Spectrum

Let us see density spectrums:

Energy Density Spectrum

Energy density spectrum can be calculated using the formula:

$$E = \int_{-\infty}^{\infty} |x(f)|^2 df$$

Power Density Spectrum

Power density spectrum can be calculated by using the formula:

$$P = \sum_{n=-\infty}^{\infty} |C_n|^2$$

Cross Correlation Function

Cross correlation is the measure of similarity between two different signals.

Consider two signals $x_1 t$ and $x_2 t$. The cross correlation of these two signals $R_{12}(\tau)$ is given by

$$\begin{aligned} R_{12}(\tau) &= \int_{-\infty}^{\infty} x_1(t) x_2(t - \tau) dt && [+ve \text{ shift}] \\ &= \int_{-\infty}^{\infty} x_1(t + \tau) x_2(t) dt && [-ve \text{ shift}] \end{aligned}$$

If signals are complex then

$$\begin{aligned} R_{12}(\tau) &= \int_{-\infty}^{\infty} x_1(t) x_2^*(t - \tau) dt && [+ve \text{ shift}] \\ &= \int_{-\infty}^{\infty} x_1(t + \tau) x_2^*(t) dt && [-ve \text{ shift}] \end{aligned}$$

$$R_{21}(\tau) = \int_{-\infty}^{\infty} x_2(t)x_1^*(t - \tau) dt \quad [+ve \text{ shift}]$$

$$= \int_{-\infty}^{\infty} x_2(t + \tau)x_1^*(t) dt \quad [-ve \text{ shift}]$$

Properties of Cross Correlation Function of Energy and Power Signals

- Auto correlation exhibits conjugate symmetry i.e. $R_{12}(\tau) = R_{21}^*(-\tau)$.
- Cross correlation is not commutative like convolution i.e.

$$R_{12}(\tau) \neq R_{21}(-\tau)$$

- If $R_{12}0 = 0$ means, if $\int_{-\infty}^{\infty} x_1(t)x_2^*(t)dt = 0$, then the two signals are said to be orthogonal.

For power signal if $\lim_{T \rightarrow \infty} \frac{1}{T} \int_{-\frac{T}{2}}^{\frac{T}{2}} x(t)x^*(t) dt$ then two signals are said to be orthogonal.

- Cross correlation function corresponds to the multiplication of spectrums of one signal to the complex conjugate of spectrum of another signal. i.e.

$$R_{12}(\tau) \longleftrightarrow X_1(\omega)X_2^*(\omega)$$

This also called as correlation theorem.

Parsvel's Theorem

Parsvel's theorem for energy signals states that the total energy in a signal can be obtained by the spectrum of the signal as

$$E = \frac{1}{2\pi} \int_{-\infty}^{\infty} |X(\omega)|^2 d\omega$$

Note: If a signal has energy E then time scaled version of that signal xat has energy E/a.

DISTORTION LESS TRANSMISSION

Transmission is said to be distortion-less if the input and output have identical wave shapes. i.e., in distortion-less transmission, the input $x(t)$ and output $y(t)$ satisfy the condition:

$$y(t) = Kx(t - t_d)$$

Where t_d = delay time and

$$k = \text{constant.}$$

Take Fourier transform on both sides

$$\begin{aligned} \text{FT}[y(t)] &= \text{FT}[Kx(t - t_d)] \\ &= K \text{FT}[x(t - t_d)] \end{aligned}$$

According to time shifting property,

$$= KX(\omega)e^{-j\omega t_d}$$

$$\therefore Y(\omega) = KX(\omega)e^{-j\omega t_d}$$

Thus, distortionless transmission of a signal $x(t)$ through a system with impulse response $h(t)$ is achieved when

$$|H(\omega)| = K \text{ and } \textit{amplituderresponse}$$

$$\Phi(\omega) = -\omega t_d = -2\pi f t_d \textit{ phaseresponse}$$

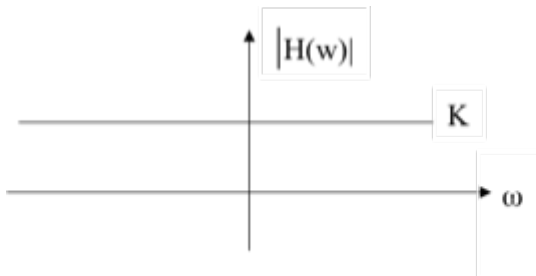

Amplitude response

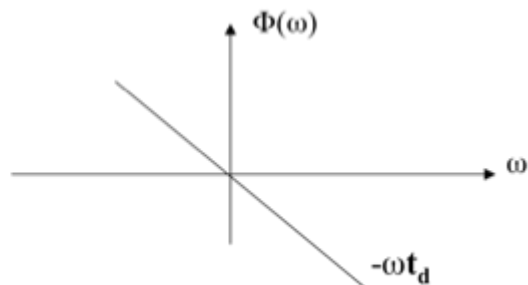

Phase response

A physical transmission system may have amplitude and phase responses as shown below:

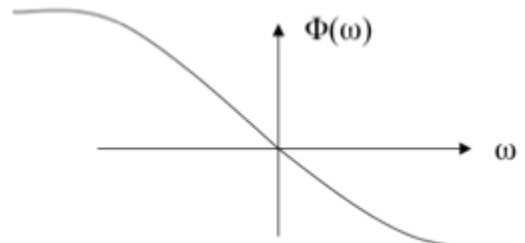
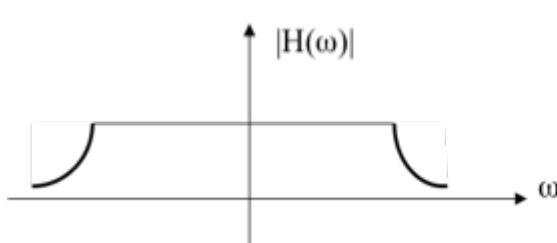

UNIT 5 - LAPLACE TRANSFORM

Complex Fourier transform is also called as Bilateral Laplace Transform. This is used to solve differential equations. Consider an LTI system excited by a complex exponential signal of the form $x(t) = Ge^{st}$.

Where $s =$ any complex number $= \sigma + j\omega$,

$\sigma =$ real of s , and

$\omega =$ imaginary of s

The response of LTI can be obtained by the convolution of input with its impulse response i.e.

$$\begin{aligned}y(t) &= x(t) \times h(t) = \int_{-\infty}^{\infty} h(\tau) x(t - \tau) d\tau \\&= \int_{-\infty}^{\infty} h(\tau) Ge^{s(t-\tau)} d\tau \\&= Ge^{st} \cdot \int_{-\infty}^{\infty} h(\tau) e^{-s\tau} d\tau\end{aligned}$$

$$y(t) = Ge^{st} \cdot H(S) = x(t) \cdot H(S)$$

Where $HS =$ Laplace transform of $h(\tau) = \int_{-\infty}^{\infty} h(\tau) e^{-s\tau} d\tau$

Similarly, Laplace transform of $x(t) = X(S) = \int_{-\infty}^{\infty} x(t) e^{-st} dt \dots \dots (1)$

Relation between Laplace and Fourier transforms

Laplace transform of $x(t) = X(S) = \int_{-\infty}^{\infty} x(t) e^{-st} dt$

Substitute $s = \sigma + j\omega$ in above equation.

$$\begin{aligned}\rightarrow X(\sigma + j\omega) &= \int_{-\infty}^{\infty} x(t) e^{-(\sigma + j\omega)t} dt \\&= \int_{-\infty}^{\infty} [x(t) e^{-\sigma t}] e^{-j\omega t} dt \\ \therefore X(S) &= F.T[x(t) e^{-\sigma t}] \dots \dots (2) \\ X(S) &= X(\omega) \quad \text{for } s = j\omega\end{aligned}$$

Inverse Laplace Transform

You know that $X(S) = F.T[x(t) e^{-\sigma t}]$

$$\begin{aligned}\rightarrow x(t) e^{-\sigma t} &= F.T^{-1}[X(S)] = F.T^{-1}[X(\sigma + j\omega)] \\&= \frac{1}{2\pi} \int_{-\infty}^{\infty} X(\sigma + j\omega) e^{j\omega t} d\omega \\ x(t) &= e^{\sigma t} \frac{1}{2\pi} \int_{-\infty}^{\infty} X(\sigma + j\omega) e^{j\omega t} d\omega \\&= \frac{1}{2\pi} \int_{-\infty}^{\infty} X(\sigma + j\omega) e^{(\sigma + j\omega)t} d\omega \dots \dots (3)\end{aligned}$$

Here, $\sigma + j\omega = s$

$$jd\omega = ds \rightarrow d\omega = ds/j$$

$$\therefore x(t) = \frac{1}{2\pi j} \int_{-\infty}^{\infty} X(s)e^{st} ds \dots \dots (4)$$

Equations 1 and 4 represent Laplace and Inverse Laplace Transform of a signal $x(t)$.

Conditions for Existence of Laplace Transform

Dirichlet's conditions are used to define the existence of Laplace transform. i.e.

- The function $f(t)$ has finite number of maxima and minima.
- There must be finite number of discontinuities in the signal $f(t)$, in the given interval of time.
- It must be absolutely integrable in the given interval of time. i.e.

$$\int_{-\infty}^{\infty} |f(t)| dt < \infty$$

Initial and Final Value Theorems

If the Laplace transform of an unknown function $x(t)$ is known, then it is possible to determine the initial and the final values of that unknown signal i.e. $x(t)$ at $t=0^+$ and $t=\infty$.

Initial Value Theorem

Statement: if $x(t)$ and its 1st derivative is Laplace transformable, then the initial value of $x(t)$ is given by

$$x(0^+) = \lim_{s \rightarrow \infty} sX(s)$$

Final Value Theorem

Statement: if $x(t)$ and its 1st derivative is Laplace transformable, then the final value of $x(t)$ is given by

$$x(\infty) = \lim_{s \rightarrow \infty} sX(s)$$

LAPLACE TRANSFORMS PROPERTIES

The properties of Laplace transform are:

Linearity Property

$$\text{If } x(t) \xrightarrow{\text{L.T}} X(s)$$

$$\& y(t) \xrightarrow{\text{L.T}} Y(s)$$

Then linearity property states that

$$ax(t) + by(t) \xrightarrow{\text{L.T}} aX(s) + bY(s)$$

Time Shifting Property

$$\text{If } x(t) \xrightarrow{\text{L.T}} X(s)$$

Then time shifting property states that

$$x(t - t_0) \xrightarrow{\text{L.T}} e^{-st_0} X(s)$$

Frequency Shifting Property

$$\text{If } x(t) \xrightarrow{\text{L.T}} X(s)$$

Then frequency shifting property states that

$$e^{s_0 t} \cdot x(t) \xrightarrow{\text{L.T}} X(s - s_0)$$

Time Reversal Property

$$\text{If } x(t) \xrightarrow{\text{L.T}} X(s)$$

Then time reversal property states that

$$x(-t) \xrightarrow{\text{L.T}} X(-s)$$

Time Scaling Property

$$\text{If } x(t) \xrightarrow{\text{L.T}} X(s)$$

Then time scaling property states that

$$x(at) \xrightarrow{\text{L.T}} \frac{1}{|a|} X\left(\frac{s}{a}\right)$$

Differentiation and Integration Properties

$$\text{If } x(t) \xrightarrow{\text{L.T}} X(s)$$

Then differentiation property states that

$$\frac{dx(t)}{dt} \xleftrightarrow{\text{L.T}} s \cdot X(s)$$

$$\frac{d^n x(t)}{dt^n} \xleftrightarrow{\text{L.T}} (s)^n \cdot X(s)$$

The integration property states that

$$\int x(t) dt \xleftrightarrow{\text{L.T}} \frac{1}{s} X(s)$$

$$\int \int \dots \int x(t) dt \xleftrightarrow{\text{L.T}} \frac{1}{s^n} X(s)$$

Multiplication and Convolution Properties

$$\text{If } x(t) \xleftrightarrow{\text{L.T}} X(s)$$

$$\text{and } y(t) \xleftrightarrow{\text{L.T}} Y(s)$$

Then multiplication property states that

$$x(t) \cdot y(t) \xleftrightarrow{\text{L.T}} \frac{1}{2\pi j} X(s) * Y(s)$$

The convolution property states that

$$x(t) * y(t) \xleftrightarrow{\text{L.T}} X(s) \cdot Y(s)$$

REGION OF CONVERGENCE *ROC*

The range variation of σ for which the Laplace transform converges is called region of convergence.

Properties of ROC of Laplace Transform

- ROC contains strip lines parallel to $j\omega$ axis in s-plane.

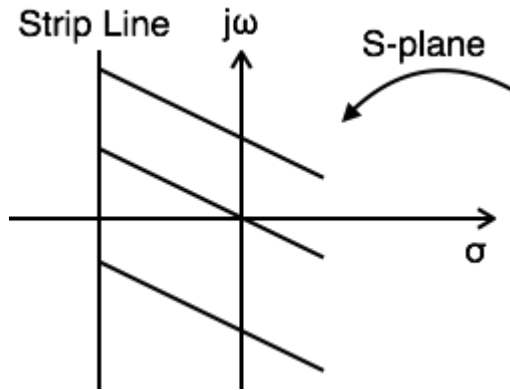

- If $x(t)$ is absolutely integrable and it is of finite duration, then ROC is entire s-plane.
- If $x(t)$ is a right-sided sequence then ROC : $\text{Re}\{s\} > \sigma_0$.
- If $x(t)$ is a left-sided sequence then ROC : $\text{Re}\{s\} < \sigma_0$.
- If $x(t)$ is a two-sided sequence then ROC is the combination of two regions.

ROC can be explained by making use of examples given below:

Example 1: Find the Laplace transform and ROC of $x(t) = e^{-at} u(t)$

$$L.T[x(t)] = L.T[e^{-at} u(t)] = \frac{1}{s+a}$$

$$\text{Re} > -a$$

$$\text{ROC} : \text{Re} s > -a$$

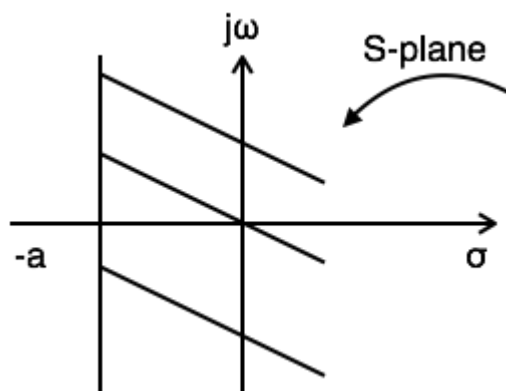

Example 2: Find the Laplace transform and ROC of $x(t) = e^{at} u(-t)$

$$L.T[x(t)] = L.T[e^{at} u(-t)] = \frac{1}{s-a}$$

$$\text{Re} < a$$

$$\text{ROC} : \text{Re} s < a$$

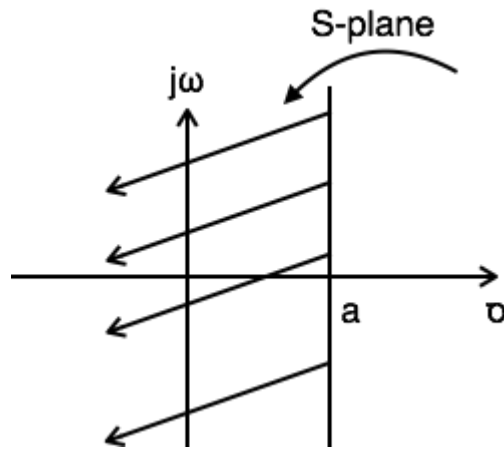

Example 3: Find the Laplace transform and ROC of $x(t) = e^{-at}u(t) + e^{at}u(-t)$

$$L.T[x(t)] = L.T[e^{-at}u(t) + e^{at}u(-t)] = \frac{1}{s+a} + \frac{1}{s-a}$$

For $\frac{1}{s+a} \text{Re}\{s\} > -a$

For $\frac{1}{s-a} \text{Re}\{s\} < a$

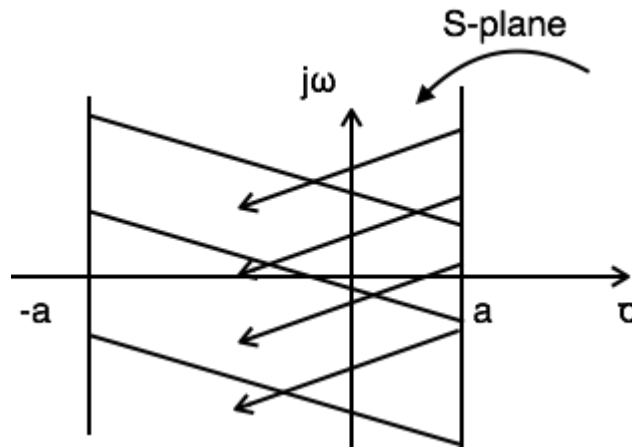

Referring to the above diagram, combination region lies from -a to a. Hence,

$ROC : -a < \text{Re}s < a$

Causality and Stability

- For a system to be causal, all poles of its transfer function must be right half of s-plane.

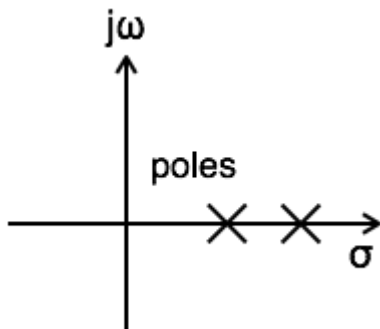

- A system is said to be stable when all poles of its transfer function lay on the left half of s-plane.

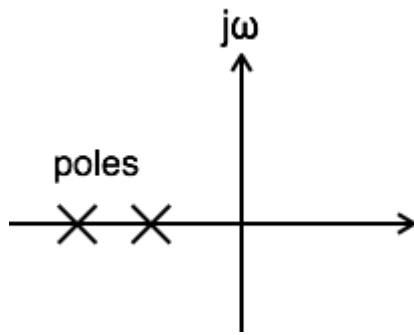

- A system is said to be unstable when at least one pole of its transfer function is shifted to the right half of s-plane.

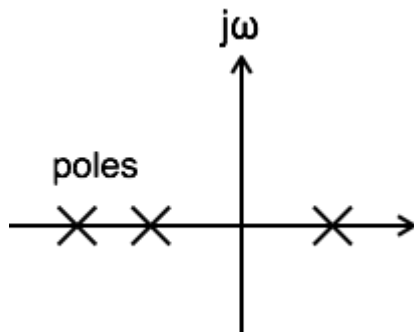

- A system is said to be marginally stable when at least one pole of its transfer function lies on the $j\omega$ axis of s-plane.

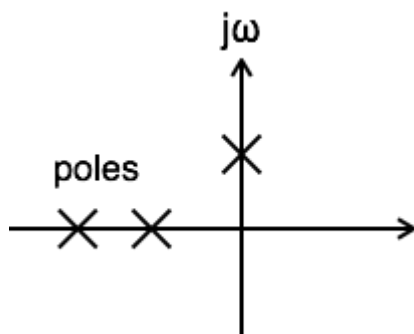

ROC of Basic Functions

$f(t)$	$F(s)$	ROC
$u(t)$	$\frac{1}{s}$	ROC: $\text{Re}\{s\} > 0$
$t u(t)$	$\frac{1}{s^2}$	ROC: $\text{Re}\{s\} > 0$
$t^n u(t)$	$\frac{n!}{s^{n+1}}$	ROC: $\text{Re}\{s\} > 0$
$e^{at} u(t)$	$\frac{1}{s - a}$	ROC: $\text{Re}\{s\} > a$

$e^{-at} u(t)$	$\frac{1}{s+a}$	ROC: $\text{Re}\{s\} > -a$
$e^{at} u(t)$	$-\frac{1}{s-a}$	ROC: $\text{Re}\{s\} < a$
$e^{-at} u(-t)$	$-\frac{1}{s+a}$	ROC: $\text{Re}\{s\} < -a$
$t e^{at} u(t)$	$\frac{1}{(s-a)^2}$	ROC: $\text{Re}\{s\} > a$
$t^n e^{at} u(t)$	$\frac{n!}{(s-a)^{n+1}}$	ROC: $\text{Re}\{s\} > a$
$t e^{-at} u(t)$	$\frac{1}{(s+a)^2}$	ROC: $\text{Re}\{s\} > -a$
$t^n e^{-at} u(t)$	$\frac{n!}{(s+a)^{n+1}}$	ROC: $\text{Re}\{s\} > -a$
$t e^{at} u(-t)$	$-\frac{1}{(s-a)^2}$	ROC: $\text{Re}\{s\} < a$
$t^n e^{at} u(-t)$	$-\frac{n!}{(s-a)^{n+1}}$	ROC: $\text{Re}\{s\} < a$
$t e^{-at} u(-t)$	$-\frac{1}{(s+a)^2}$	ROC: $\text{Re}\{s\} < -a$
$t^n e^{-at} u(-t)$	$-\frac{n!}{(s+a)^{n+1}}$	ROC: $\text{Re}\{s\} < -a$

$$\frac{e^{-at} \cos bt}{(s+a)^2 + b^2}$$

$$\frac{e^{-at} \sin bt}{(s+a)^2 + b^2}$$

Z-TRANSFORMS

Analysis of continuous time LTI systems can be done using z-transforms. It is a powerful mathematical tool to convert differential equations into algebraic equations.

The bilateral *twosided* z-transform of a discrete time signal x_n is given as

$$Z.T[x(n)] = X(Z) = \sum_{n=-\infty}^{\infty} x(n)z^{-n}$$

The unilateral *onesided* z-transform of a discrete time signal x_n is given as

$$Z.T[x(n)] = X(Z) = \sum_{n=0}^{\infty} x(n)z^{-n}$$

Z-transform may exist for some signals for which Discrete Time Fourier Transform *DTFT* does not exist.

Concept of Z-Transform and Inverse Z-Transform

Z-transform of a discrete time signal x_n can be represented with XZ , and it is defined as

$$X(Z) = \sum_{n=-\infty}^{\infty} x(n)z^{-n} \dots \dots (1)$$

If $Z = re^{j\omega}$ then equation 1 becomes

$$\begin{aligned} X(re^{j\omega}) &= \sum_{n=-\infty}^{\infty} x(n)[re^{j\omega}]^{-n} \\ &= \sum_{n=-\infty}^{\infty} x(n)[r^{-n}]e^{-j\omega n} \end{aligned}$$

$$X(re^{j\omega}) = X(Z) = F.T[x(n)r^{-n}] \dots \dots (2)$$

The above equation represents the relation between Fourier transform and Z-transform.

$$X(Z)|_{z=e^{j\omega}} = F.T[x(n)].$$

Inverse Z-transform

$$X(re^{j\omega}) = F.T[x(n)r^{-n}]$$

$$x(n)r^{-n} = F.T^{-1}[X(re^{j\omega})]$$

$$\begin{aligned} x(n) &= r^n F.T^{-1}[X(re^{j\omega})] \\ &= r^n \frac{1}{2\pi} \int X(re^{j\omega})e^{j\omega n} d\omega \\ &= \frac{1}{2\pi} \int X(re^{j\omega})[re^{j\omega}]^n d\omega \dots \dots (3) \end{aligned}$$

Substitute $re^{j\omega} = z$.

$$dz = jre^{j\omega} d\omega = jz d\omega$$

$$d\omega = \frac{1}{j} z^{-1} dz$$

Substitute in equation 3.

$$3 \rightarrow x(n) = \frac{1}{2\pi} \int X(z) z^n \frac{1}{j} z^{-1} dz = \frac{1}{2\pi j} \int X(z) z^{n-1} dz$$

$$X(Z) = \sum_{n=-\infty}^{\infty} x(n) z^{-n}$$

$$x(n) = \frac{1}{2\pi j} \int X(z) z^{n-1} dz$$

Z-TRANSFORMS PROPERTIES

Z-Transform has following properties:

Linearity Property

$$\text{If } x(n) \xleftrightarrow{\text{Z.T}} X(Z)$$

$$\text{and } y(n) \xleftrightarrow{\text{Z.T}} Y(Z)$$

Then linearity property states that

$$a x(n) + b y(n) \xleftrightarrow{\text{Z.T}} a X(Z) + b Y(Z)$$

Time Shifting Property

$$\text{If } x(n) \xleftrightarrow{\text{Z.T}} X(Z)$$

Then Time shifting property states that

$$x(n - m) \xleftrightarrow{\text{Z.T}} z^{-m} X(Z)$$

Multiplication by Exponential Sequence Property

$$\text{If } x(n) \xleftrightarrow{\text{Z.T}} X(Z)$$

Then multiplication by an exponential sequence property states that

$$a^n \cdot x(n) \xleftrightarrow{\text{Z.T}} X(Z/a)$$

Time Reversal Property

$$\text{If } x(n) \xleftrightarrow{\text{Z.T}} X(Z)$$

Then time reversal property states that

$$x(-n) \xleftrightarrow{\text{Z.T}} X(1/Z)$$

Differentiation in Z-Domain OR Multiplication by n Property

$$\text{If } x(n) \xleftrightarrow{\text{Z.T}} X(Z)$$

Then multiplication by n or differentiation in z-domain property states that

$$n^k x(n) \xleftrightarrow{\text{Z.T}} [-1]^k z^k \frac{d^k X(Z)}{dZ^k}$$

Convolution Property

$$\text{If } x(n) \xleftrightarrow{\text{Z.T}} X(Z)$$

and $y(n) \xleftrightarrow{Z.T} Y(Z)$

Then convolution property states that

$$x(n) * y(n) \xleftrightarrow{Z.T} X(Z) \cdot Y(Z)$$

Correlation Property

If $x(n) \xleftrightarrow{Z.T} X(Z)$

and $y(n) \xleftrightarrow{Z.T} Y(Z)$

Then correlation property states that

$$x(n) \otimes y(n) \xleftrightarrow{Z.T} X(Z) \cdot Y(Z^{-1})$$

Initial Value and Final Value Theorems

Initial value and final value theorems of z-transform are defined for causal signal.

Initial Value Theorem

For a causal signal xn , the initial value theorem states that

$$x(0) = \lim_{z \rightarrow \infty} X(z)$$

This is used to find the initial value of the signal without taking inverse z-transform

Final Value Theorem

For a causal signal xn , the final value theorem states that

$$x(\infty) = \lim_{z \rightarrow 1} [z - 1]X(z)$$

This is used to find the final value of the signal without taking inverse z-transform.

Region of Convergence *ROC* of Z-Transform

The range of variation of z for which z-transform converges is called region of convergence of z-transform.

Properties of ROC of Z-Transforms

- ROC of z-transform is indicated with circle in z-plane.
- ROC does not contain any poles.
- If xn is a finite duration causal sequence or right sided sequence, then the ROC is entire z-plane except at $z = 0$.
- If xn is a finite duration anti-causal sequence or left sided sequence, then the ROC is entire z-plane except at $z = \infty$.
- If xn is a infinite duration causal sequence, ROC is exterior of the circle with radius a . i.e. $|z| > a$.
- If xn is a infinite duration anti-causal sequence, ROC is interior of the circle with radius a . i.e. $|z| < a$.
- If xn is a finite duration two sided sequence, then the ROC is entire z-plane except at $z = 0$ & $z = \infty$.

The concept of ROC can be explained by the following example:

Example 1: Find z-transform and ROC of $a^n u[n] + a^{-n} u[-n - 1]$

$$Z.T[a^n u[n]] + Z.T[a^{-n} u[-n - 1]] = \frac{Z}{Z-a} + \frac{Z}{Z-\frac{1}{a}}$$

$$ROC : |z| > a \quad ROC : |z| < \frac{1}{a}$$

The plot of ROC has two conditions as $a > 1$ and $a < 1$, as you do not know a .

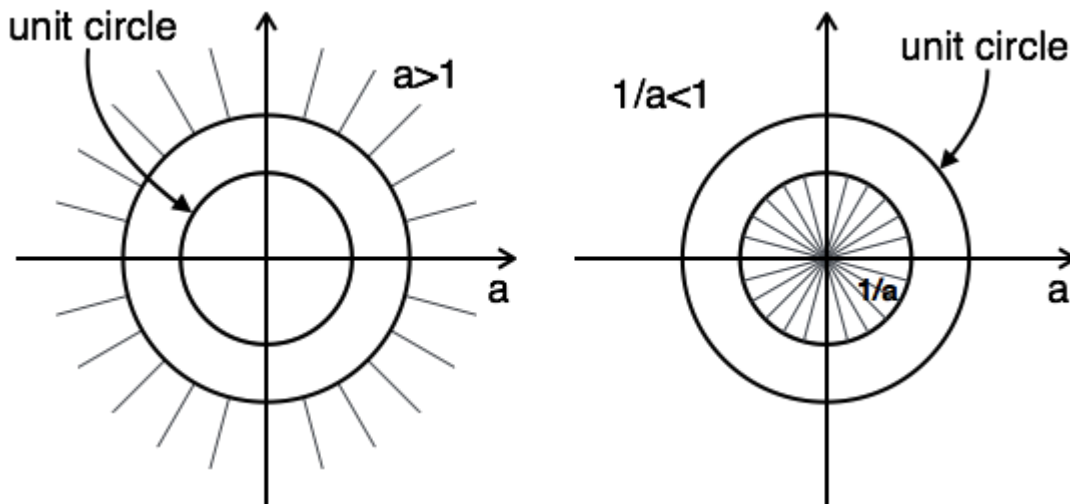

In this case, there is no combination ROC.

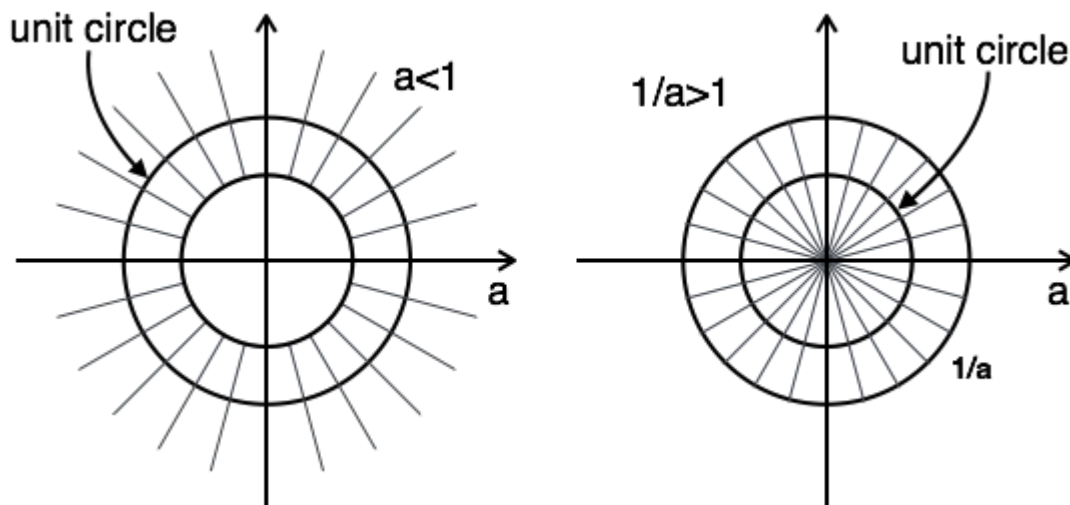

Here, the combination of ROC is from $a < |z| < \frac{1}{a}$

Hence for this problem, z-transform is possible when $a < 1$.

Causality and Stability

Causality condition for discrete time LTI systems is as follows:

A discrete time LTI system is causal when

- ROC is outside the outermost pole.
- In The transfer function $H[Z]$, the order of numerator cannot be greater than the order of denominator.

Stability Condition for Discrete Time LTI Systems

A discrete time LTI system is stable when

- its system function $H[Z]$ include unit circle $|z|=1$.
- all poles of the transfer function lay inside the unit circle $|z|=1$.

Z-Transform of Basic Signals

$x[n]$	$X[Z]$
$\delta[n]$	1
$u[n]$	$\frac{Z}{Z-1}$
$u[-n-1]$	$-\frac{Z}{Z-1}$
$\delta[n-m]$	z^{-m}
$a^n u[n]$	$\frac{Z}{Z-a}$
$a^n u[-n-1]$	$-\frac{Z}{Z-a}$
$n a^n u[n]$	$\frac{aZ}{ Z-a ^2}$
$n a^n u[-n-1]$	$-\frac{aZ}{ Z-a ^2}$
$a^n \cos \omega n u[n]$	$\frac{Z^2 - aZ \cos \omega}{Z^2 - 2aZ \cos \omega + a^2}$
$a^n \sin \omega n u[n]$	$\frac{aZ \sin \omega}{Z^2 - 2aZ \cos \omega + a^2}$