

Predictive Tools in Evaluating Re-Entrainment of Exhausted Particulate in Different Ventilator Configurations for Different Heat Process Applications

Siegmar U. Baltuch and Edmund G. Baltuch
Air-Therm Inc.
5801 Monkland Avenue, Suite 8,
Montreal, Quebec, Canada H4A 1G4

Keywords: Green Ventilation, Gravity Ventilation, Ridge Ventilation, Stack Effect, Smelter Design, Environmental Health Safety and Environment Predictive Tools, Thermodynamic Analysis, Computational Fluid Dynamics

ABSTRACT

Selection of proper roof ventilators to match application and environment standards is key to both smelter function and interior working conditions. Computational fluid dynamic simulations can predicatively demonstrate to end users and assist engineers, coupled with traditional calculations and physical modeling, in the optimization of smelter ventilation reducing total installed costs while assuring that the proper solution is in place for the complete lifecycle of the process equipment and manpower that will spend many man-hours working. Our research and practice has developed number ventilation methods, which can be predicatively verified utilizing CFD simulation techniques.

Results have been fully implemented on a number of smelter applications and we continue to study, optimize and innovate as new tools become available to provide the best possible engineered solutions for particular applications

DISCUSSION

The objective of this research project is to review whether information available to reduction cell building designers can assist them in optimizing their ability to reduce the sporadic re-entrainment of exhausted particulate. A very high percentage of reduction cell particulate is captured by highly effective gas treatment equipment. However a percentage of fumes are mixed with air and exhausted through the buildings gravity roof ventilators. It is the researcher's point of view that there is an ethical responsibility to take whatever reasonable steps possible to reduce the potential effects of exhausted particulate. As engineers our job is the application of science and wherever possible the optimization of processes to make something more efficient and effective.

Much of the research conducted for this project was conducted as part of contracts by Air-Therm Inc. for the engineering, supply and installation of gravity ventilators for greenfield and brownfield smelters and was therefore covered by confidentiality agreements. Therefore no specific part of the reduction cell process, its ventilation requirements or other elements of the technologies are discussed.

That being said it is important to note that this research was conducted on buildings designed for Rio Tinto

Alcan AP Technology, such as AP30, AP3x, AP40 and even AP60 reduction cells that views proper ventilation for both reduction cells and potrooms as part of their global smelter design

For the hot process building of an aluminium smelter to function, heat has to be extracted from the inside of buildings. This is done by having air inlets at the bottom of buildings and outlets at the apex of buildings. The reason for this is to maximize the potential chimney effect. When using stack (buoyancy) effect ventilation, the process heat becomes the driver and therefore increasing this distance (height) improves the ability of the heated airstream to utilize basic gravity for acceleration of the heat/air flow, this allows a regular number of air changes per hour within the plant environments all while ensuring that the process environment remains weather resistant under process operating conditions.

This process has been understood at least from the time King Charles I of England decreed in 1600 that castle rooms should have 10 foot ceilings and that windows should be taller than wider to allow better smoke extraction

In 1914 the American Society of Heating and Ventilation Engineers (the predecessor of ASHRAE) published that 50 cubic meters of air per hour per human was a minimal standard. The 2004 ASHRAE/ANSI standard 62.1-2004¹ has been optimized to 42.4 cubic meters of renewed or fresh air per hour per human. This ASHRAE standard relies on the National Ambient Air Quality Secondary Standard for airborne particulate at 60 $\mu\text{g}/\text{m}^3$ with a mean 24 hour maximum of 150 $\mu\text{g}/\text{m}^3$.

Natural ventilation occurs by two different means: First, wind driven natural ventilation, where the topography of the building is studied to create a building shape where either by pressure or suction, the warm air within the building is drawn to the exterior. This system is reliant on a particular constant minimal wind factor (C_w), which can generally not be assumed for most industrial building applications

Second, stack effect natural ventilation, where the differential of temperature and pressure between two bodies of air creates buoyancy in the air stream of the air body within the process building. This sort of system must work in all wind conditions, including under zero wind conditions.

In the case of reduction cell buildings the air is brought through nominally continuous inlet opening on each lengthwise side of the building envelope. Inside the building the air splits with a portion of the air going to a reduction cell basement and the rest up to a mezzanine where it enters the Potroom through claustra walls. There is grating round each of the reduction cells which allow air to come up and around each reduction cell. Nominally 6.5 to 7.0 MWth is required per tonne of metal. As shown in Figure 1.

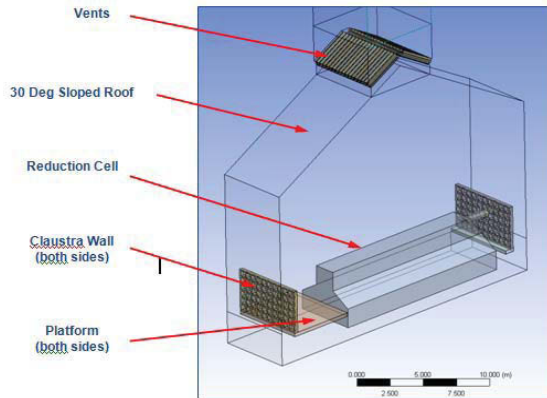

Figure 1. General Layout of Reduction Cell in Building

Within the building there exists a neutral plane. Below this line air is drawn into the building, above this line air is exhausted the larger the distance between in the ingress and egress, the greater the chimney effect (therefore the velocity of air and therefore the total quantity of heat that can be extracted from the inside of the process building).

Gravity ventilation is a form of stack effect ventilation that requires no power source. A process building is a building within which a heat producing transformation of materials is taking place, such as the smelting of non ferrous metals, hot rolling process of creating steel, or the production of glass products.

Within the buildings a very high quantity of heat (as described in kilowatts or British thermal units) is produced and must be exhausted to conform to state and national building standards and in a number of cases state and national hygiene standards.

The purpose of this ventilation system (air inlet, grating and gravity ventilators) is for the extraction of heat by means of air exchange. Control and abatement of process released gases and particulate should be handled by advanced process equipment defined as the gas treatment center.

According to gas treatment center supplier Fives Solios, their most efficient capturing technology has HF capture rates of 0.3 mg/Nm³. Utilizing their dual suction YPRIOS, Solios is claiming a fluorine emissions optimal reduced to 0.3 kg per ton of aluminium produced. According to Broek

(November 2012), warmer climates, however, are more likely to achieve only 0.6 mg/Nm³ due to the negative impact of temperature and humidity

Environmental impacts studies were carried out on a 545 000 tonne capacity smelter. Using state of the art, industry accepted laser fluoride detectors on non point sources including the reduction building ventilators and carbon bake furnace building ventilators emission verifications were taken over a number of 36 hour periods to achieve accurate data.

The 2009 study, which has been corroborated by others studies on this facility and similar recent analysis of other pre bake reduction cell smelters, discovered that fluoride emissions at the reduction building roof ventilators averaged 0.45mg/Nm³. Based on total averaged airflow through the reduction building roof ventilators, a nominal quantity of fluoride per year is being emitted through the ventilators. This has to be compared with the massive amount of air gas being handled by the smelter's roof ventilators to arrive at the tonnage emitted for each application and location.

Most of hot gases exhausted through the gravity roof ventilators are lofted high enough into the environment and then greatly dissipated to an almost insignificant parts per billion rate of gases. However, the interior environment of the reduction cell buildings requires a constant flow of fresh inlet air and that all means should be taken to reduce the re-entrainment of an air gas mix that already is loaded with a certain concentration of fluorine. The issue remains that under what conditions and under what types of configurations is re-entrainment more likely and under what conditions and configurations is extraction and dissipation of airborne particulate more likely.

The aluminium smelter construction industry is located all over of the world and therefore there a number of suppliers each with their own designs. Certain geographic areas are still using outdated or homemade configurations. In the case of this research project the author looked at the 2 most modern and prevalent used designs: Tulip shaped ventilators as engineered by Air-Therm Inc. and several types of low profile designs as engineered by Air-Therm. Air-Therm has both patents and trademark protections on its design for Canada and elsewhere in the world and therefore use of its proprietary shapes cannot be utilized without licensing or permission.

Air-Therm's tulip shaped gravity roof ventilator is called the VG Gravitec. It consists nominally of a 100% free area throat stack, a covered central roof section and two specialized designed asymmetrically rounded wind bands sections that are open to at least the throat's 100% free area as can be seen in Figure 2. The tulip design consists of a structural frame, corrugated cladding and internal gutters made of light gauge sheet metal. The frames can be re-clad if required giving the smelter potline buildings an extended life cycle. Each application design is depended on specific location variables however overall height of the ventilators tends to be nominally 150% of throat opening.

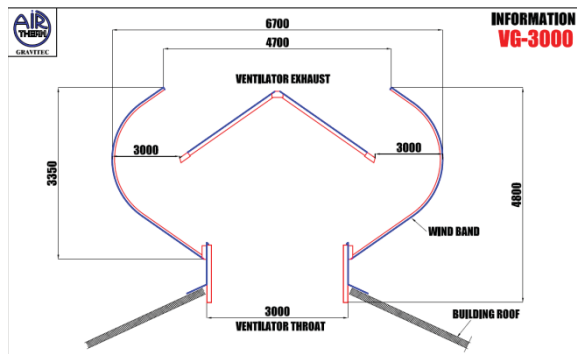

Figure 2 Configuration of Tulip shape ventilator

Air-Therm has developed a series of low profile design ventilators dating back to the 1960s. These ventilators consist of sheet metal boxes with a series of baffles and gutters that allow for nominally 50% free area all while being weather resistant under positive smelter operating conditions. If the low profile module begin corroding due to the smelter environment, they may require complete replacement of affect modules. The low profile designs are nominally 500 to 900 mm in height. Figure 3.

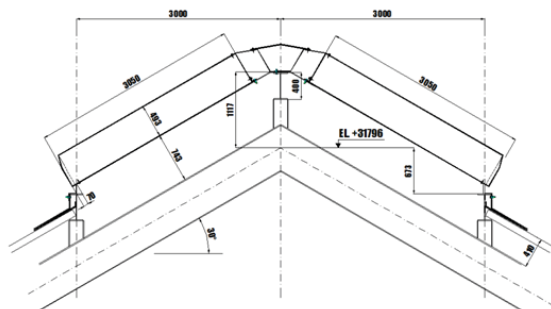

Figure 3 Configuration of Low Profile shape ventilator

A driving factor in the decision to construct new smelter capacity is the reduction in total installed construction costs. Low profile ventilators are less expensive (supply cost) and have a significantly lower dead and live load forces on the building's structure, therefore requiring project to supply buildings with a significantly lighter and therefore less expensive building roof structure.

METHODOLOGY

Computational fluid dynamics involves the discretization of the solution domain into finite volumes (control volumes) and the subsequent solving of the Navier-Stokes (conservation of momentum), conservation of mass, and conservation of energy equations. In addition, in this case, the buoyancy forces are also being considered. The commercial CFD software Fluent version 13.0.0 – SP2 was

used for the analysis. Fluent is a well known CFD solver that has been benchmarked for many types of problems. Based on the positive results utilizing this system we are currently upgrading to the next level of solver called CFX.

TESTING AND UNDERSTANDING CFD SIMULATION AS A RELEVANT TOOL

This research project has been carried out utilizing a quantitative research methodology. After an audit of available resources and the creation of a pilot project (one shot experimental case study), which would give rapid prognosis, and observing the strong potential for a successful result, a pretest-post test control group design for a complete project roll out was executed.

By assuming that all engineering technologists and engineers are equal we can declare that in equal groups the manpower required for the study were fully randomized. Due to the nature of the particular project, it was possible to have a control group working side by side with the group implementing the experimental system. It was immediately obvious to know who was part of the experimental group and who was not.

Basically one group used had access to internal; and external CFD resources and the other did not. Being in an engineering office together, both teams immediately recognized that management was implementing a test system. From an engineering standpoint this meant assembling the required information and specification, designing a system specific to the proposed application, implementing the system and then verifying the performance, using empirical data. The assumption was that the CFD model would give a more precise and visual result which should be comparable to hand calculations and physical model research.

MODEL DESCRIPTION

In this particular comparative application, Air-Therm VG-Series ventilator and a number of Air-Therm Low Profile models were positioned at the top the smelter application with a particular height of from ground to ventilator inlet (throat). The dimensions are identified in Figure 3 below. Figure 4 shows the details of the potential Air-Therm ventilators. In the CFD model, the ventilators were simplified in order to keep the mesh size reasonable, however, the important dimensions such as flow areas were maintained similar to those of the actual ventilators.

Sitting on top of the same building, with the same height roof pitch, process conditions and external ambient conditions both ventilation configuration were simulated.

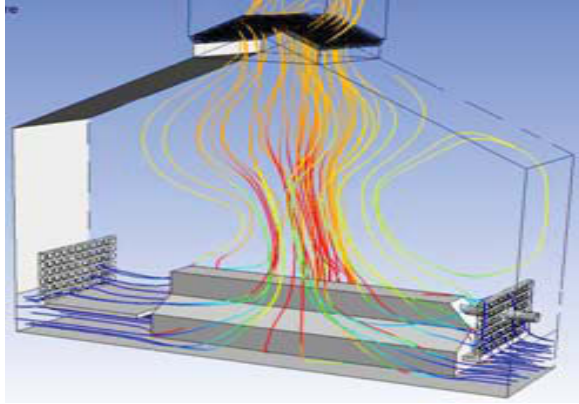

Figure 4 Low Profile Simulation

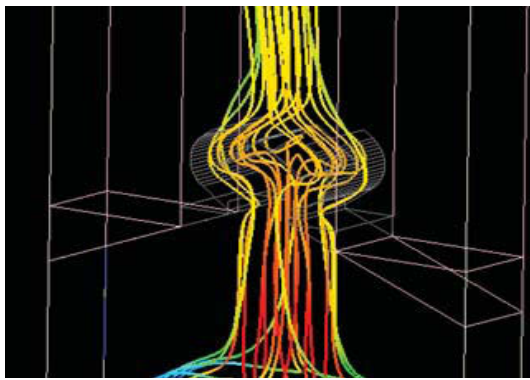

Figure 5 Tulip Shape Simulation

In the case of the VG tulip model there was a static pressure drop of approximately 4,5 Pa. In the case of the low profile designs there was a pressure drop of approximately 16 Pa. Simulations were carried out multiple times and due to modeling factors there are always nominally different results; however, all simulations demonstrated very similar characteristics with similar effects and pressure drops. Considerations reviewed were location of the stack relative to flow separations, building stack height and the design slope of the building roof. For the purpose of this study the Potroom buildings were considered the tallest surrounding structures, disregarding design of gas treatment buildings or vertical paste plants.

Because of the higher pressure differential between internal and external environmental conditions this differential did not affect in any way the low profile ventilators ability to exhaust the specified heat load or be weather resistant under operating conditions (this is another study not covered in this research paper). However we detected that in the low profile model, due to the higher static pressure drop, there is a higher chance of gas re-entrainment due to downwash within the smelter envelope or due to lower exhaust velocities, when encountering specific wind conditions or cold weather conditions. The gases may follow the leeward side of the building roof and re-enter the potroom through the leeward side air inlet openings or

alternatively be pulled into the windward side of adjoining leeward buildings.

This was confirmed by the 2009 study that utilized CALMET, an advanced non steady state diagnostic three dimensional meteorological model with micro-meteorological modules for overland boundary areas, a TAPM (air pollution model) and CALPUFF v6.0, non steady state lagrangian, gaussian puff mode containing parameterization for complex terrain effects building downwash and simple chemical transformation. The study also used a building profile input program (BPIP) and was simulated industrial source complex (ISC-PRIME) method.

Increased exit velocities and decreased static pressure drops were demonstrated to allow for higher dispersion of extracted plume. Analysis bore out that Wilson's (1979) (Figure 6) design procedure for required stack height to avoid contamination, Turner (1994) (Figure 7) coordinate for showing Gaussian distribution and ASHRAE 2003 (Figure 8) flow recirculation regions and exhaust to intake distances are valid when selecting an optimized gravity roof ventilation configuration for a Potroom application.

This demonstrates that our modeling, work conducted by other researchers and earlier hand calculation methods would arrive at similar results and conclusions.

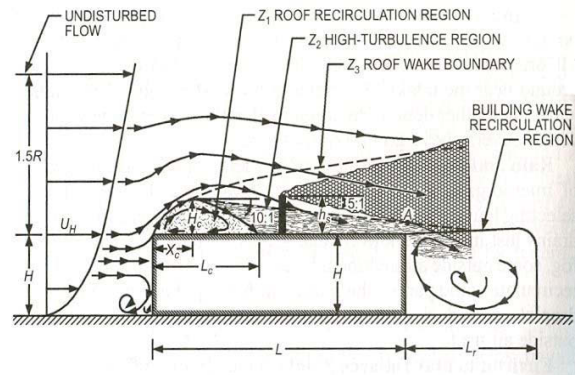

Figure 6 Wilson (1979)

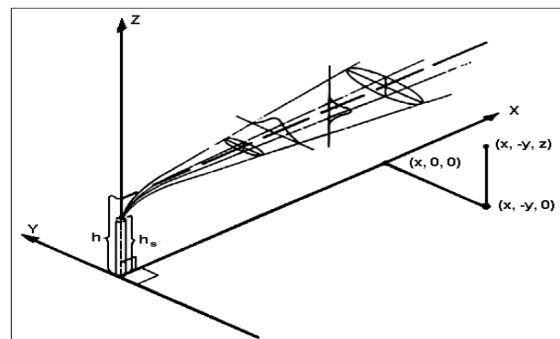

Figure 7 Gaussian Distribution (Turner 1994)

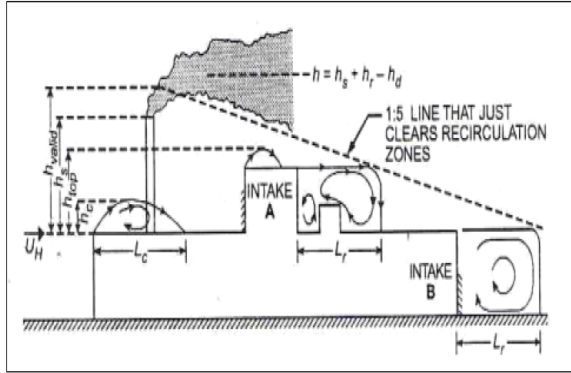

Figure 8 Flow Recirculation ASHRAE 2003

According to our simulated model, the percentage of reentrainment appears to be small in percentage, however, when the health and safety of the potroom work force is to be considered we believe that further study and practical comparative analysis is warranted.

Limitations

Computational fluid dynamic (CFD) models that attempt to resolve airflow around buildings by solving Navier-Stokes are able to give accurate model of internal and inflow models. However, it is more difficult to utilize CFD model to accurately predict airflows in a mixed open environment. Computational Wind Engineering (CWE), due to the size of the models remains a tool for general guidance. This is due to variance and prediction inaccuracies. Direct Numerical Simulation (DNS) requires significant computing capacity and due to its complexity is not an available tool for the designing practitioner. Large Eddy Simulation (LES) and detached eddy simulation (DES) will eventually be other tools to understand the potential re-entrainment of exhausted gases.

Combining CFD simulation with physical modeling experimentation, hand calculations and field measure of existing smelter facilities will give the engineering practitioner the best approach to optimizing their ventilation design, allowing for the reasonable and feasible application of available information and science.

Conclusion

With the advent and availability of affordable and practical CFD solutions, optimization in design is possible in the early stages of project planning that allow for both better understanding of safety concerns, possible design optimization and back up of empirical calculation and physical modeling results. We have found that in its current state CFD technology can be considered as a “just in time” technology for the design, health safety and environment as explained in figure 9.

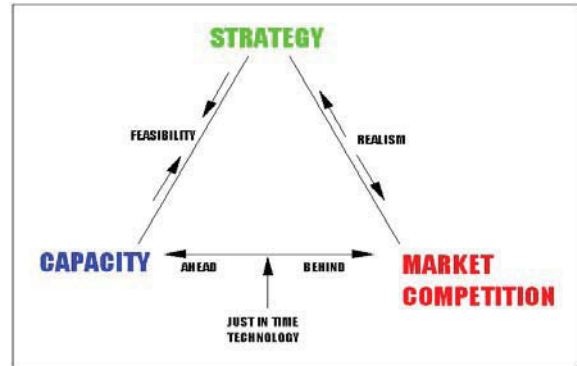

Figure 9

This study demonstrates that beyond the historical and correct use of empirical calculation and physical modeling, affordable and available technologies are improving our ability as engineers to deliver needed information and produce the best possible engineered result.

Both tulip shape and low profile, depending on specific applications, locations, weather conditions, economic models of building life have demonstrated in the field that they perform or exceed performance for the specified ventilation of reduction cells with designed Potroom buildings. We believe that there remains significant research and field work to be carried out to further understand complete extraction of maximum particulate through the ventilators into the environment, how dissipation of exhaust occurs and the potential for re-entrainment through the leeward side air inlets or the windward side of adjoining potlines.

A design team can now request to see different sizing and types of ventilators to gauge the potential results, can adjust and move the location of air inlets and even potentially adjust the location of process equipment to improve air guidance performance for man, machinery and the smelting Aluminium.

REFERENCES

1. American Society of Heating Refrigeration and Air Conditioning Engineers 2001. ASHRAE/ANSI Standard 62-2001 (Atlanta).
2. M. Dupuis, “Turbulence Modeling of Air Circulation in an Enclosure with Multiple Openings and Local Heat Sources”, Proceedings of the 32nd Annual Conference of CIM, Computer Software Section, 1993 229-236.
3. H.B. Awbi “Application of Computational Fluid Dynamics in Room Ventilation”, Building and Environment, 24 (1): 73-84 (1989).
4. L. Davidson; “Ventilation by Displacement in a Three Dimensional Room-A Numerical Study”: Building and Environment, 24 (4): 363-372 (1989).

5. <http://www.fivesgroup.com/fivessolios/en/expertise/Reduction/GasTreatmentCenters/Pages/DualSuctionSystem.aspx>
6. Buonicore, AJ and WT Davis (eds.). 1992. Air Pollution Engineering Manual. New York: Van Nostrand Reinhold/Air and Waste Management Association.
7. American Society of Heating Refrigeration and Air Conditioning Engineers 2003 ASHRAE/Flow Recirculation (Atlanta).
8. Boyne Smelter Limited Environmental Environmental Investigation Ref: STAT349 Investigation Report 30 September 2009.
9. S. Broek, How To “De-Bottleneck” A Smelter Ventilation System, Aluminium International Today, December 2012.