

# CHAPTER 1

## Introduction

### 1.1 WHY THIS BOOK?

“Things should be made as simple as possible but not a bit simpler than that.”

*Albert Einstein (Safir and Safire 1982)*

Finding the Einstein threshold of optimum simplicity was a constant goal for the author when writing this book (Figure 1.1).

The first driving force for writing it was the coming of age of unsaturated soil mechanics: There was a need to introduce geotechnical engineering as dealing with true three-phase soils while treating saturated soil as a special case, rather than the other way around. The second driving force was to cover as many geotechnical engineering topics as reasonably possible in an introductory book, to show the vast domain covered by geotechnical engineering and its important contributions to society. Dams, bridges, buildings, pavements, landfills, tunnels, and many other infrastructure elements involve geotechnical engineering. The intended audience is anyone who is starting in the field of geotechnical engineering, including university students.

### 1.2 GEOTECHNICAL ENGINEERING

Geotechnical engineering is a young (~100 years) professional field dealing with soils within a few hundred meters

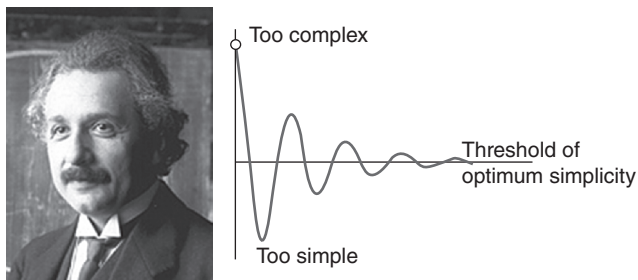

**Figure 1.1** Einstein threshold of optimum simplicity. (Photo by Ferdinand Schmutzer)

of a planet’s surface for the purpose of civil engineering structures. For geotechnical engineers, soils can be defined as loosely bound to unbound, naturally occurring materials that cover the top few hundred meters of a planet. In contrast, rock is a strongly bound, naturally occurring material found within similar depths or deeper. At the boundary between soils and rocks are intermediate geo-materials. The classification tests and the range of properties described in this book help to distinguish between these three types of naturally occurring materials.

Geotechnical engineers must make decisions in the best interest of the public with respect to safety and economy. Their decisions are related to topics such as:

- Foundations
- Slopes
- Retaining walls
- Dams
- Landfills
- Tunnels

These structures or projects are subjected to loads, which include:

- Loads from a structure
- Weight of a slope
- Push on a retaining wall
- Environmental loads such as waves, wind, rivers, earthquakes, floods, droughts, and chemical changes, among others

Note that current practice is based on testing an extremely small portion of the soil or rock present in the project area. A typical soil investigation might involve testing 0.001% of the soil that will provide the foundation support for the structure. Yet, on the basis of this extremely limited data, the geotechnical engineer must predict the behavior of the entire mass of soil. This is why geotechnical engineering is a very difficult discipline.

### 1.3 THE PAST AND THE FUTURE

While it is commonly agreed that geotechnical engineering started with the work of Karl Terzaghi at the beginning of the 20th century, history is rich in instances where soils and soils-related engineering played an important role in the evolution of humankind (Kerisel 1985; Peck 1985; Skempton 1985). In prehistoric times (before 3000 BC), soil was used as a building material. In ancient times (3000–300 BC), roads, canals, and bridges were very important to warriors. In Roman times (300 BC–300 AD), structures started to become larger and foundations could no longer be ignored. The Middle Ages (AD 300–1400) were mainly a period of war, in which structures became even heavier, including castles and cathedrals with very thick walls. Severe settlements and instabilities were experienced. The Tower of Pisa was started in 1174 and completed in 1370. The Renaissance (AD 1400–1650) was a period of enormous development in the arts, and several great artists proved to be great engineers as well. This was the case of Leonardo da Vinci and more particularly Michelangelo. Modern times (AD 1650–1900) saw significant engineering development, with a shift from military engineering to civil engineering. In 1776, Charles Coulomb developed his earth pressure theory, followed in 1855 by Henry Darcy and his seepage law. In 1857, William Rankine proposed his own earth pressure theory, closely followed by Carl Culman and his graphical earth pressure solution. In 1882, Otto Mohr presented his stress theory and the famous Mohr circle, and in 1885 Joseph Boussinesq provided the solution to an important elasticity problem for soils. From 1900 to 2000 was the true period of development of modern geotechnical engineering, with the publication of Karl Terzaghi's book *Erdbaumechanik* (in 1925), which was soon translated into English; new editions were co-authored with Ralph Peck beginning in 1948. The progress over the past 50 years has been stunning, with advances in the understanding of fundamental soil behavior and associated soil models (e.g., unsaturated soils), numerical simulations made possible by the computer revolution, the development of large machines

(e.g., drill rigs for bored piles), and a number of ingenious ideas (e.g., reinforced earth walls).

Geotechnical engineering has transcended the ages because all structures built on or in a planet have to rest on a soil or rock surface; as a result, the geotechnical engineer is here to stay and will continue to be a very important part of humanity's evolution. The Tower of Pisa is one of the most famous examples of a project that did not go as planned, mostly because of the limited knowledge extant some 900 years ago. Today designing a proper foundation for the Tower of Pisa is a very simple exercise, because of our progress. One cannot help but project another 900 years ahead and wonder what progress will have been made. Will we have:

- complete nonintrusive site investigation of the entire soil volume?
- automated four-dimensional (4D) computer-generated design by voice recognition and based on a target risk?
- tiny and easily installed instruments to monitor geotechnical structures?
- unmanned robotic machines working at great depth?
- significant development of the underground?
- extension of projects into the sea?
- soil structure interaction extended to thermal and magnetic engineering?
- failures down to a minimum?
- expert systems to optimize repair of defective geotechnical engineering projects?
- geospace engineering of other planets?
- geotechnical engineers with advanced engineering judgment taught in universities?
- no more lawyers, because of the drastic increase in project reliability?

### 1.4 SOME RECENT AND NOTABLE PROJECTS

Among some notable geotechnical engineering projects and developments are the underpinning of the foundation of the Washington Monument in 1878 (Figure 1.2; Briaud et al.

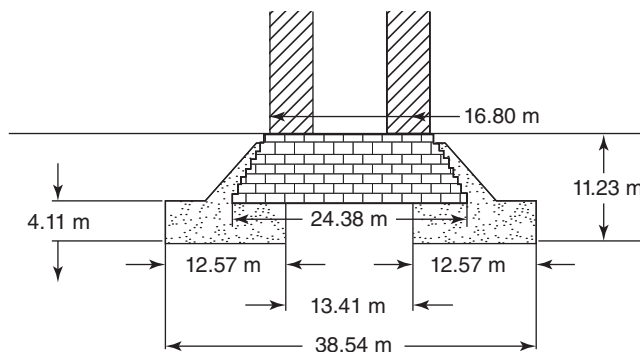

Figure 1.2 The Washington Monument.



**Figure 1.3** Culebra cut of the Panama Canal, 1913. (a: Courtesy of Fernando Alvarado; b: Courtesy of United States Geological Survey)

2009); the Panama Canal (1913) and its slope stability problems (Figure 1.3; Marcuson 2001); the Tower of Pisa (1310) and its foundation repair in 1990 (Figure 1.4; Jamiolkowski 2001); the locks and dams on the Mississippi River and their gigantic deep foundations (Figure 1.5); and airports built offshore, as in the case of the Tokyo Haneda airport runway extension (Figure 1.6). Among the most significant milestones

in the progress of geotechnical engineering are the discovery of the effective stress principle in saturated and then unsaturated soil mechanics; the development of laboratory testing and in situ testing to obtain fundamental soil properties; the combination of soil models with numerical methods to simulate three-dimensional behavior; the advent of geosynthetics and of reinforced soil, which is to geotechnical

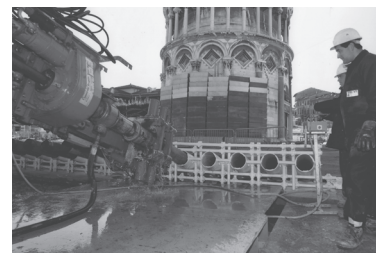
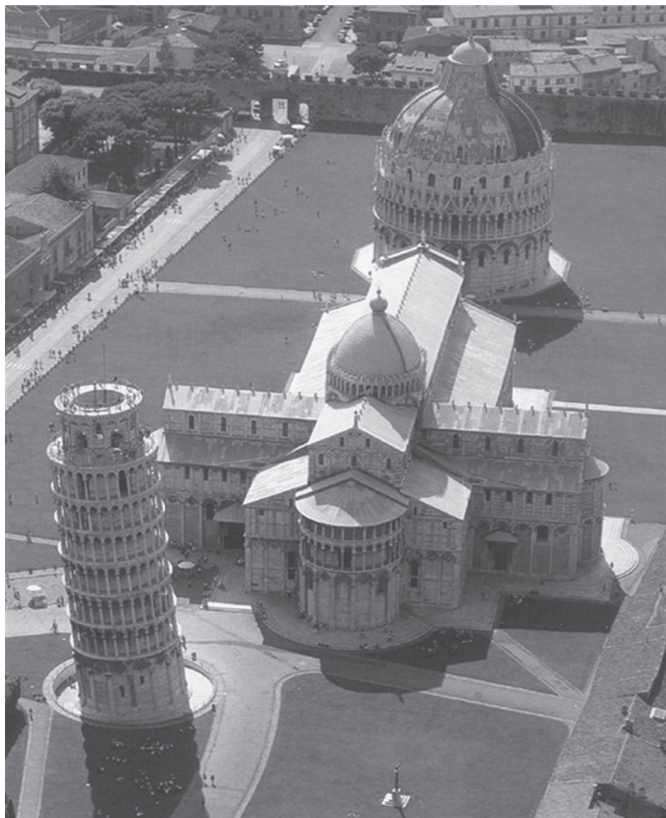

**Figure 1.4** The Tower of Pisa and its successful repair in 1995. (c: Courtesy of Dr. Gianluca De Felice (General Secretary), Opera Primaziale Pisana.)

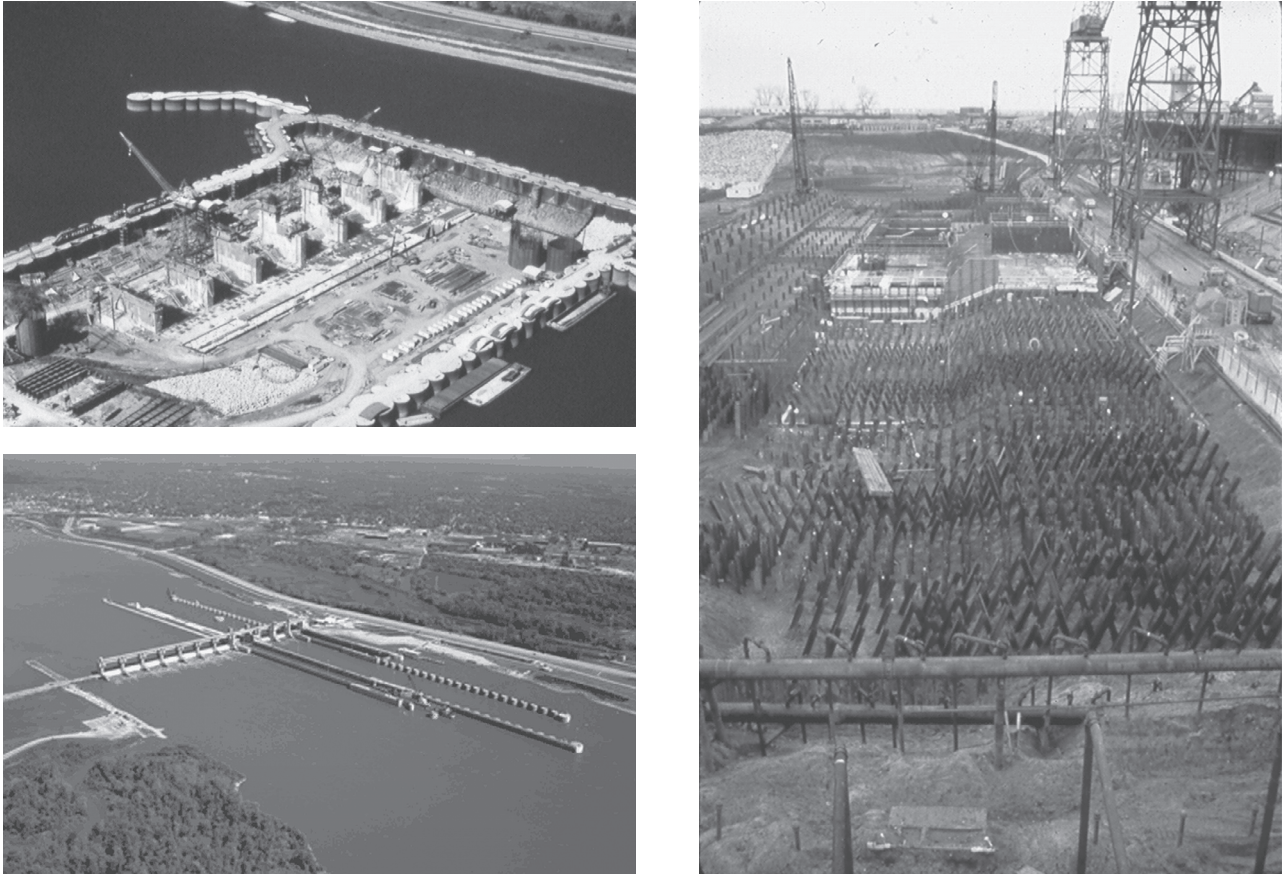

**Figure 1.5** Lock and Dam 26 on the Mississippi River in 1990. (a: Courtesy of United States Army Corps of Engineers, b: Courtesy of Thomas F. Wolff, St. Louis District Corps of Engineers, 1981. c: Courtesy of Missouri Department of Transportation.)



**Figure 1.6** Extension of the Tokyo Haneda airport in 2010. (Courtesy of Kanto Regional Development Bureau, Ministry of Land, Infrastructure, Transport and Tourism, Japan.)

engineering what reinforced concrete is to structural engineering; and the development of instruments to monitor full-scale behavior of geotechnical engineering structures.

## 1.5 FAILURES MAY OCCUR

Failures do occur. The fact remains that it is not possible to design geotechnical engineering structures that will have zero probability of failure. This is because any calculation is associated with some uncertainty; because the geotechnical engineering profession's knowledge, despite having made great strides, is still incomplete in many respects; because human beings are not error free; and because the engineer designs the geotechnical engineering structure for conditions that do not include extremely unlikely events such as an asteroid hitting the structure at the same time as an earthquake, a hurricane, and a 100-year flood during rush hour.

Nevertheless, geotechnical engineers learn a lot from failures, because thorough analysis of what happened often points out weaknesses and needed improvement in our approaches. Some of the most notable geotechnical engineering failures have been the Transcona silo bearing capacity failure in 1913 (Figure 1.7), the Teton dam seepage failure in 1976 (Figure 1.8), and the failure of some of the New Orleans levees during Hurricane Katrina in 2005 (Figure 1.9).

## 1.6 OUR WORK IS BURIED

As Terzaghi is said to have noted, there is no glory in foundations. Indeed, most of our work is buried (Figure 1.10).

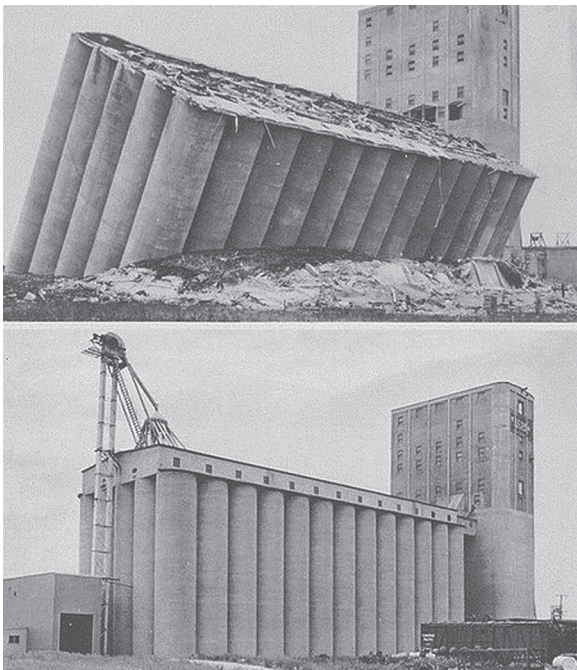

**Figure 1.7** Transcona silo bearing capacity failure and repair (1913). (Courtesy of the Canadian Geotechnical Society.)

For example, everyone knows the Eiffel Tower in Paris, but very few know about its foundation (Figure 1.11; Lemoine 2006). The foundation was built by excavating down to the water level about 7 m deep—but the soil at that depth was not strong enough to support the 100 MN weight of the Tower, so digging continued. Because of the water coming from the River Seine, the deepening of the excavation had to be done using pressurized caissons (upside-down coffee cans, big ones!) so that the air pressure could balance the water pressure and keep it out of the excavation. Workers got into these  $14 \times 6 \times 15$  m caissons (Figure 1.12) and worked literally under pressure until they reached a depth where the soil was strong enough to support the Tower (about 13 m on the side closest to the river and about 8 m on the side away from the river).

## 1.7 GEOTECHNICAL ENGINEERING CAN BE FUN

Geotechnical engineering can be fun and entertaining, as the book by Elton (1999; Figure 1.13) on geo-magic demonstrates. Such phenomena as the magic sand (watch this movie: [www.stevespanglerscience.com/product/1331?gclid=CNiW1uu-aICFc9J2godZwuiwg](http://www.stevespanglerscience.com/product/1331?gclid=CNiW1uu-aICFc9J2godZwuiwg)), water going uphill, the surprisingly strong sand pile (Figure 1.13), the swelling clay pie (Figure 1.13), and the suddenly very stiff glove full of sand will puzzle the uninitiated. Geotechnical engineering is seldom boring; indeed: the complexity of soil deposits and soil behavior can always surprise us with unanticipated results. The best geotechnical engineering work will always include considerations regarding geology, proper site characterization, sound fundamental soil mechanics principles, advanced knowledge of all the tools available, keen observation, and engineering judgment. The fact that geotechnical engineering is so complex makes this field an unending discovery process, which keeps the interest of its adepts over their lifetimes.

## 1.8 UNITS

In engineering, a number without units is usually worthless and often dangerous. On this planet, the unit system most commonly used in geotechnical engineering is the System International or SI system. In the SI system, the unit of mass is the *kilogram* (kg), which is defined as the mass of a platinum-iridium international prototype kept at the International Bureau of Weights and Measures in Paris, France. On Earth, the kilogram-mass weighs about the same as 10 small apples. The unit of length is the *meter*, defined as the length of the path travelled by light in vacuum during a time interval of  $1/299,792,458$  of a second. A meter is about the length of a big step for an average human. The *second* is the duration of 9,192,631,770 periods of the radiation corresponding to the transition between the two hyperfine levels of the ground state of the cesium 133 atom. Watches and clocks often have a hand ticking off the seconds. The unit of temperature is the



**Figure 1.8** Teton Dam seepage failure (1976) (Photos by Mrs. Eunice Olson. Courtesy of Arthur G. Sylvester.)

*Kelvin*, defined as  $1/273.16$  of the difference in temperature between the absolute zero and the triple point of water. The *degree Celsius* (C) is also commonly used; it has the same magnitude as the degree Kelvin but starts at  $\sim 0^{\circ}\text{C}$  ( $\sim 273$  K) for the freezing point of water and uses  $\sim 100^{\circ}\text{C}$  ( $\sim 373$  K) for the boiling point of water. There are seven fundamental

units in a unit system, but these four (kg, m, s, K) are the most commonly used in geotechnical engineering. The other fundamental units in the SI system are the mole (substance), the candela (light), and the ampere (electricity).

Other geotechnical engineering units are derived from these fundamental units. The unit of force is the *Newton*,



**Figure 1.9** New Orleans levee failures during the Katrina hurricane in 2005. (Courtesy of United States Army Corps of Engineers.)



**Figure 1.10** A rendition of the geotechnical engineering world. (Courtesy of Hayward Baker Inc., Geotechnical Contractor.)

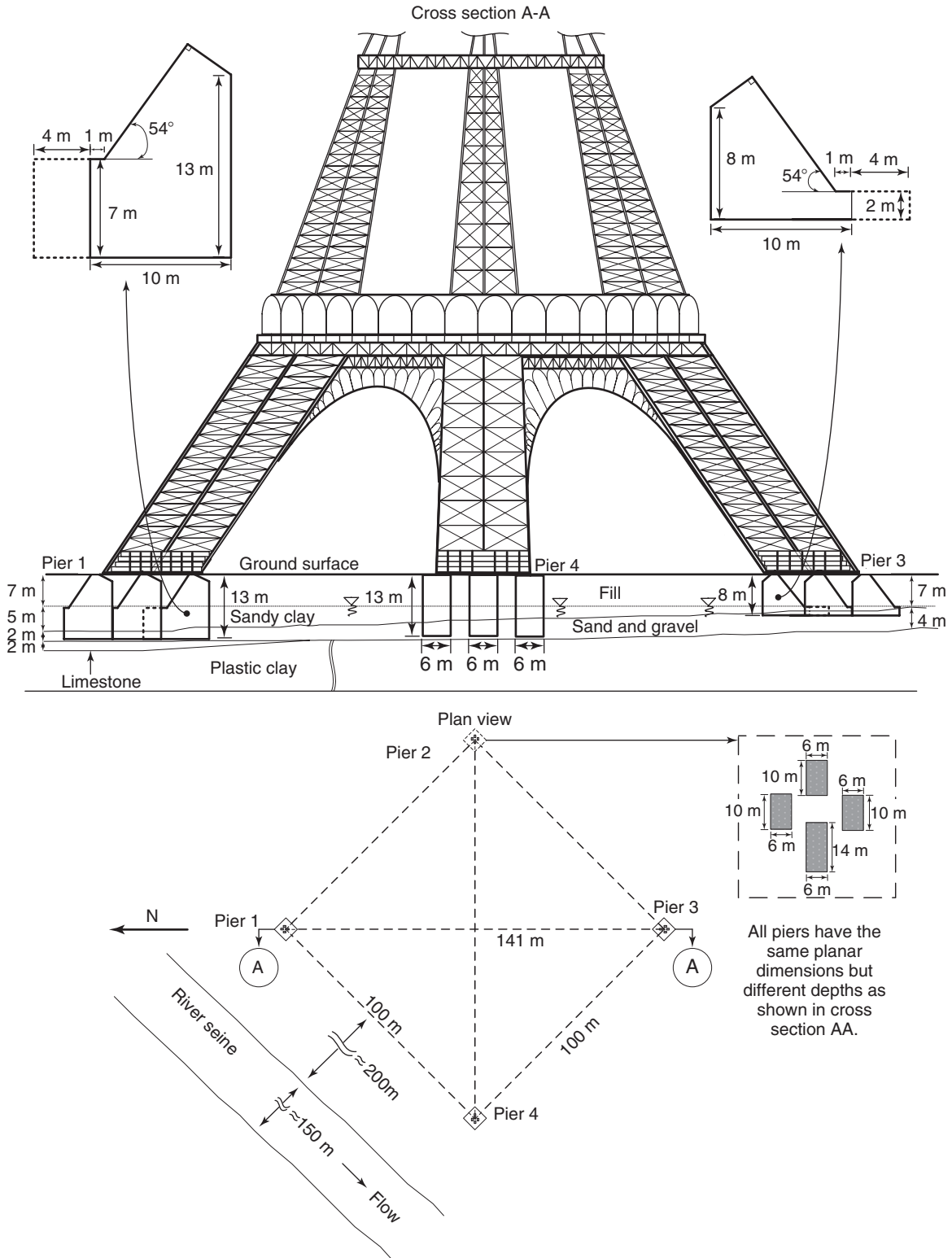
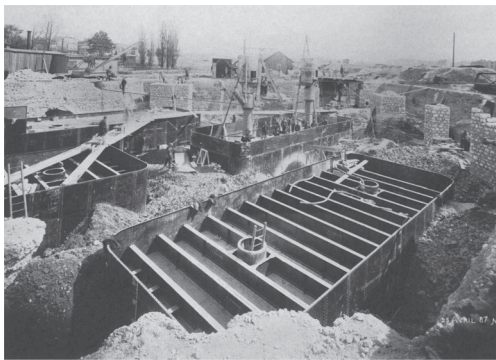

**Figure 1.11** The Eiffel Tower foundation plan.





(a)



(b)

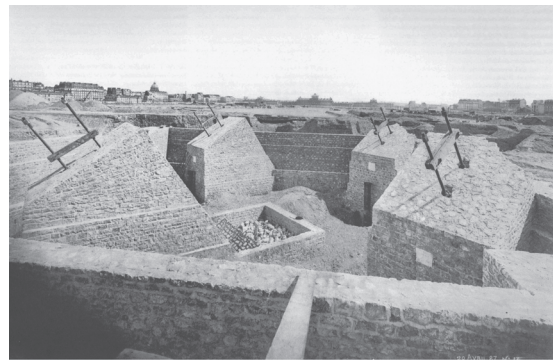

(c)

**Figure 1.12** The Eiffel Tower foundation. (Photos b, c: Courtesy of the Musée d'Orsay, Paris.)

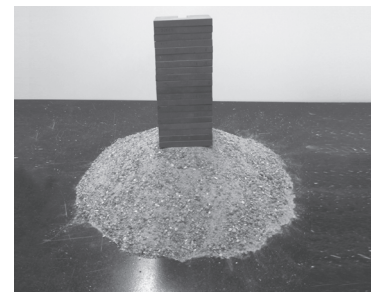
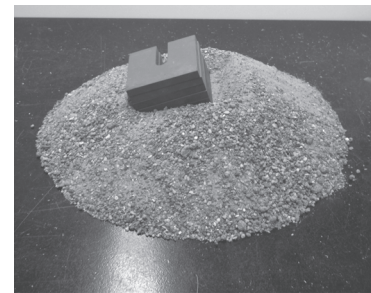
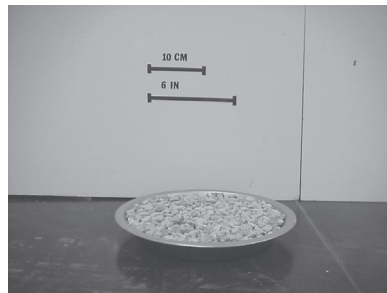

**Figure 1.13** Soil magic. (Courtesy of David J. Elton.)

which is the force required to accelerate a mass of 1 kg to 1 m/s<sup>2</sup>.

$$1 \text{ N} = 1 \text{ kg} \times 1 \text{ m/s}^2 \quad (1.1)$$

This force is about the weight of a small apple. Humans typically weigh between 600 and 1000 N. Most often the kilo-Newton (kN) is used rather than the Newton. The kilogram force is the weight of one kilogram mass. On Earth, the equation is:

$$1 \text{ kgf} = 1 \text{ kg} \times 9.81 \text{ m/s}^2 \quad (1.2)$$

The unit of stress is the kN/m<sup>2</sup>, also called kilo-Pascal (kPa); there is about 20 kPa under your feet when you stand on both feet. Note that a kilogram force is the weight of a kilogram mass and depends on what planet you are on and

even where you are on Earth. Other units are shown in a table at the beginning of this book.

Accepted multiples of units, also called SI prefixes, are:

terra	10 <sup>12</sup>
giga	10 <sup>9</sup>
mega	10 <sup>6</sup>
kilo	10 <sup>3</sup>
milli	10 <sup>-3</sup>
micro	10 <sup>-6</sup>
nano	10 <sup>-9</sup>
pico	10 <sup>-12</sup>

(An angstrom is 10<sup>-10</sup> meter.)

**PROBLEMS**

- 1.1 How would you decide if you have reached the threshold of optimum simplicity?
- 1.2 What was achieved by underpinning the 608 MN Washington Monument foundation from a 24.4 m square foundation to a 38.5 m square ring, as shown in Figure 1.2?
- 1.3 How would you go about deciding if the slopes of the Panama Canal are too steep?
- 1.4 What major geotechnical engineering problems come to mind for the extension of the Tokyo Airport?
- 1.5 Write a step-by-step procedure for the up-righting of the Transcona Silo.
- 1.6 For the 100 MN Eiffel Tower, calculate the average pressure under the foundation elements.

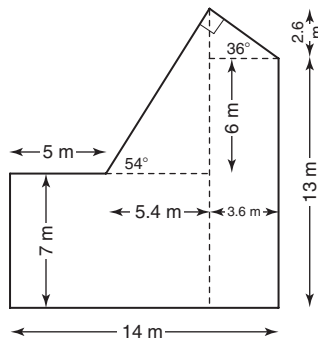

**Figure 1.1s** Foundation of the Eiffel Tower.

- 1.7 For the Tower of Pisa, calculate the pressure under the foundation, given that the foundation is a ring with a 19.6 m outside diameter and a 4.5 m inside diameter. Compare this pressure to the pressure obtained for the Eiffel Tower in problem 1.6.

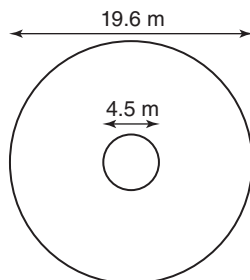

**Figure 1.2s** Tower of Pisa foundation.

1.8 Calculate the pressure under your feet.

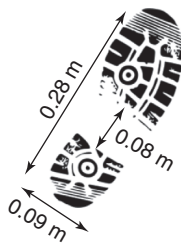

**Figure 1.3s** Feet geometry.

1.9 What do you think caused the failure of the Teton Dam? What do you think might have avoided this problem?

1.10 Explain the magic behind Figures 1.13d and 1.13e.

1.11 Are the following equations correct?

$$1 \text{ kgf} = 1 \text{ kg} \times 9.81 \text{ m/s}^2$$

$$1 \text{ N} = 1 \text{ kg} \times 1.0 \text{ m/s}^2$$

$$1 \text{ kgf} = 9.81 \text{ N}$$

1.12 What is the relationship between a kilopascal (kPa) and a pound per square foot (psf)? What is the net pressure in psf under the Eiffel Tower foundation?

## Problems and Solutions

### Problem 1.1

How would you decide if you have reached the threshold of optimum simplicity?

### Solution 1.1

The threshold is not reached if:

- The solution seems too simple or too complicated.
- The solution is not used in practice.
- It costs too much time and money to obtain the solution.
- The solution leads to erroneous answers.
- The solution does not contain or address the essential elements of the problem.

The threshold is likely reached if:

- The solution seems reasonably simple and cannot be simplified further.
- The solution is used in practice.
- The cost of obtaining and implementing the solution is consistent with the budget of a large number of projects.
- The solution leads to reasonable answers.
- The solution is based on fundamental elements of the problem.

### Problem 1.2

What was achieved by underpinning the 608 MN Washington Monument foundation from a 24.4 m square foundation to a 38.5 m square ring, as shown in Figure 1.2?

### Solution 1.2

By increasing the area of the foundation, the pressure under the Washington Monument was decreased. This allowed the construction of the column to be completed with greatly reduced settlement and avoided the overturning or collapse of the structure that would likely have occurred if no underpinning had been done.

### Problem 1.3

How would you go about deciding if the slopes of the Panama Canal are too steep?

**Solution 1.3**

I would draw a free-body diagram of the mass that would be likely to fail, I would show all the external forces, and I would check the equilibrium of the system.

I would also check the site and make observations of the slope as a function of time. If it had not already been built, I could observe neighboring slopes and make measurements.

**Problem 1.4**

What major geotechnical engineering problems come to mind for the extension of the Tokyo Airport?

**Solution 1.4**

Some of the problems associated with the extension of the Tokyo airport include:

- Soil failure in the form of rotational sliding at the edges of the embankment.
- Excessive settlement of the embankment, and in particular differential movements.
- Erosion problems during storms.
- Earthquake-induced problems, as the airport is in a high-seismicity area.

**Problem 1.5**

Write a step-by-step procedure for the up-righting of the Transcona Silo.

**Solution 1.5**

The following steps could be considered for the successful up-righting of the silo:

- Build footings on top of which hydraulic jacks can be installed to raise the structure. Make sure the footings can resist the force necessary to lift the structure.
- Lift the structure upward and start to backfill the failed soil. An alternative is to reinforce the existing failed soil.
- Complete the reinforcement of the key locations beneath the silo.
- Lower the jacks and allow the silo to rest on the reinforced earth.

**Problem 1.6**

For the 100 MN Eiffel Tower, calculate the average pressure under the foundation elements.

**Solution 1.6**

Pressure is force over area. The problem states that the Eiffel Tower exerts 100 MN of force on the foundation. From Figure 1.11, we know that the foundation of each leg of the Eiffel Tower is made of one rectangular foundation of 14 m by 6 m and three rectangular foundations of 10 m by 6 m. Therefore, the total area for the foundation of each leg is  $14 \text{ m} \times 6 \text{ m} + 3(10 \text{ m} \times 6 \text{ m}) = 264 \text{ m}^2$ . Assuming that the load is evenly distributed among the four legs, the load per leg is 100 MN divided by 4, or 25 MN. The average pressure per foundation element is

$$\frac{25000}{264} = 94$$

Note that this pressure does not include the weight of the foundation.

Weight of the largest foundation element:

$$\begin{aligned} W &= 25 \times \left( 14 \times 7 + 3.6 \times 6 + \frac{2.6 \times 3.6}{2} + \frac{5.4 \times 8.6}{2} \right) \\ &= 25 \times (98 + 21.6 + 4.68 + 23.22) \times 6 = 221 \end{aligned}$$

Average pressure due to the weight of this foundation is:

$$P_{\text{foundation}} = \frac{22125}{14 \times 6} = 263$$

which is much larger than the pressure due to the tower alone. Indeed, the weight of all the foundation elements is a lot more than the weight of the tower.

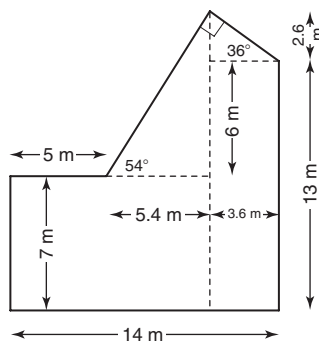

**Figure 1.1s** Foundation of the Eiffel Tower.

If we assume a total unit weight of soil of  $20 \text{ kN/m}^3$ , this pressure  $P_{\text{foundation}}$  is equivalent to the pressure created by a height of soil equal to

$$h_{\text{soil}} = \frac{263}{20} = 13$$

Because 13 meters of soil were excavated, the weight of soil removed during the excavation was approximately equal to the weight of the foundation and the net pressure increase on the soil is  $P_{\text{net}} = 94.6 \text{ kPa}$ . However, the actual pressure under the biggest foundation element is  $P_{\text{total}} = 94.6 + 263 = 357 \text{ kPa}$ .

### Problem 1.7

For the Tower of Pisa, calculate the pressure under the foundation, given that the foundation is a ring with a 19.6 m outside diameter and a 4.5 m inside diameter. Compare this pressure to the pressure obtained for the Eiffel Tower in problem 1.6.

### Solution 1.7

$$\text{Pressure under the foundation} = \frac{142 \times 10^2}{285.21} = 498$$

If this pressure does not include the weight of the foundation, then  $P_{\text{net}} = 496.8 \text{ kPa}$  is the net pressure. Net pressure under the Eiffel Tower foundation =  $94.6 \text{ kPa}$ . The net pressure under the Tower of Pisa is about five times higher than the net pressure under the Eiffel Tower.

### Problem 1.8

Calculate the pressure under your feet.

### Solution 1.8

Effective area for one foot  $\approx (0.28 - 0.08) \times 0.09 = 0.018 \text{ m}^2$

Average weight of a person =  $750 \text{ N}$

$$\text{Pressure under two feet} : \frac{750 \times 10^{-3}}{2 \times 0.018} = 20$$

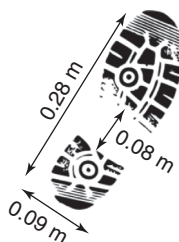

**Figure 1.3s** Feet geometry.

**Problem 1.9**

What do you think caused the failure of the Teton Dam? What do you think might have avoided this problem?

**Solution 1.9**

The failure of the Teton Dam was likely due to seepage at the boundary between the dam and the abutment. This seepage led to piping in the dam and ultimately to its breach. One way to avoid such a problem is to build a wall penetrating into the abutment, called a *key*, to minimize the seepage at that interface.

**Problem 1.10**

Explain the magic behind Figures 1.13d and 1.13e.

**Solution 1.10**

The swelling clay pie is made of smectite clay, which has a tremendous ability to attract water in the presence of a free water source. This is due to the chemical attraction between the water molecules and the smectite mineral ( $\text{Al}_2\text{Si}_4\text{O}_{10}(\text{OH})_2$  and  $x$  interlayers of  $\text{H}_2\text{O}$ ). This clay type can swell an amount equal to its initial height or more. This is why the clay pie swelled to twice its height when subjected to a water source.

The sand pile at the top of the figure fails under the load applied (50 N) because the load exceeds the shear strength of the sand. The sand pile at the bottom of the figure is internally reinforced by sheets of toilet paper that are not visible from the outside. These paper sheets provide enough tension and increased shear strength in the sand for it to resist a much higher load (220 N) than the unreinforced sand pile.

**Problem 1.11**

Are the following equations correct?

**Solution 1.11**

$$1 \text{ kgf} = 1 \text{ kg} \times 9.81 \text{ m/s}^2: \text{Correct}$$

$$1 \text{ N} = 1 \text{ kg} \times 1.0 \text{ m/s}^2: \text{Correct}$$

$$1 \text{ kgf} = 9.81 \text{ N}: \text{Correct}$$

**Problem 1.12**

What is the relationship between a kilopascal (kPa) and a pound per square foot (psf)?

**Solution 1.12**

$$1 \text{ kPa} = 1000 \text{ N/m}^2 = \frac{\left(1000 \text{ N} \times \frac{0.22481 \text{ lb}}{1 \text{ N}}\right)}{\left(1 \text{ m}^2 \times \left(\frac{3.28 \text{ ft}}{1 \text{ m}}\right)^2\right)} = 20.9 \text{ psf}$$

What is the net pressure in psf under the Eiffel Tower foundation?

$$\text{Total weight} = 100 \text{ MN}$$

$$\text{Total area} = (14 \text{ m} \times 6 \text{ m} + 3(10 \text{ m} \times 6 \text{ m})) \times 4 = 10$$

$$\begin{aligned} \text{Pressure in kPa} &= \frac{100 \text{ MN}}{1056 \text{ m}^2} = \frac{100 \times 10^6}{1056 \text{ N/m}^2} \\ &= 94697 \text{ N/m}^2 = 94 \end{aligned}$$

$$\text{Pressure in psf} = 94.7 \text{ kPa} \times 20.9(\text{psf/kPa}) = 1975$$